

SMA Connectors Series



Content.....	Page
Description	2
Interface Dimensions	2
Interface Dimensions in mm/inches	2
Characteristics	3
Cable Connectors	4
PCB Connectors	11
Panel Receptacles	13
Adapter Connectors	18
Termination	25
Assembly Instruction	26

Description

SMA is an acronym for SubMiniature version A and was developed in the 1960's. Its compact design, high durability and outstanding electrical performance have made it one of the most widely used connectors in RF and Microwave applications. Normally utilized in frequency ranges from DC-18 GHz, there are also precision versions that can work effectively up to 26.5 GHz.

SMA is a 50 ohm impedance connector with a threaded interface for increased reliability and is suitable for a wide range of applications. It is also available in Reverse Polarity (RP) versions, where the male and female interface is switched.

Interface Dimensions

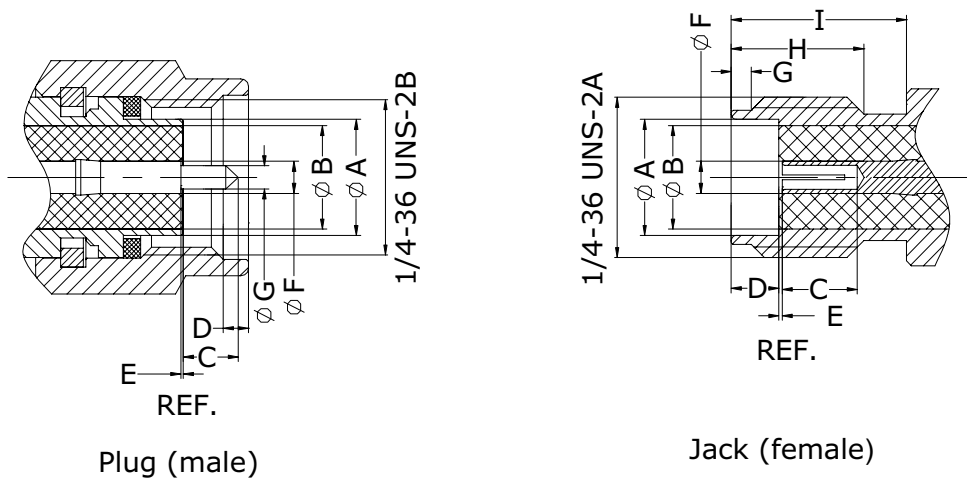

Interface Dimensions (mm/inches)

	Plug		Jack	
	min.	max.	min.	max.
A	-	4.59/.181	4.59/.181	-
B	-	4.18/.165	-	4.18/.165
C	-	2.54/.100	2.67/.105	-
D	0.38/.015	1.14/.045	1.88/.074	1.98/.078
E	0.00/.000	0.25/.010	0.00/.000	0.25/.010
F	1.24/.049	1.29/.051	1.24/.049	1.29/.051
G	0.90/.036	0.94/.037	0.38/.015	1.14/.045
H	-	-	4.32/.170	-
I	-	-	5.54/.218	-

Interface dimensions conformable to the standards:

International: **IEC 60169-15**
 Europe: **CECC 22110**
 USA: **MIL-C-39012, SMA**
Interface MIL-STD-348a/310
 GB: **BS 9210 N 0006**
 F: **NF-C-93563(KMR)**

Characteristics

ELECTRICAL	REQUIREMENTS
Impedance	50
Frequency range	DC to 18 GHz
Dielectric Withstanding Voltage	2500 V rms 50 Hz, sea level
Working Voltage	≤1,000 V rms 50 Hz, sea level
VSWR	Straight connector, .141": ≤1.23 (DC~18GHZ)
	Straight connector, RG316: ≤1.19 (DC~6GHZ)
	Right angle connector, .141": ≤1.39 (DC~18GHZ)
	Right angle connector, RG316: ≤1.28 (DC~6GHZ)
Insulation Resistance	5×10 ³ MΩ min.(initial)
Contact Resistance	
- Center contact	3.0 m max..
- Outer contact	2.5 m max.
RF-leakage	
DC to 3 GHz	-90 dB min.
3 GHz to 6 GHz	-75 dB min.

MECHANICAL	REQUIREMENTS
Recommended Coupling Nut Torque	Standard: 0.8 Nm~1.1 Nm / 7.1~9.7 in. lbs Brass: 0.45 Nm /4.0 in. lbs
Coupling Nut Retention Force	≥270 N /60.7 lbs
Contact Captivation	Axial: ≥27 N/6.1 lbs
Cable Retention Force	
- cable 2.6/50	110 N/25 lbs
- cable 5/50	150 N/33.75 lbs (single braid) 200 N/48 lbs (double braid)
-cable .085/50	135 N/30 lbs
-cable .141	270 N/60.75 lbs
Durability (Mating Cycles)	500 min.

ENVIRONMENTAL	REQUIREMENTS
Temperature Range	-65°C to +165°C
Climactic Category	IEC→55/155/21
Corrosion	Salt spray test acc. to MIL-STD-202, Method 101, Condition B
Moisture Resistance	MIL-STD-202 F, Method 106
Vibration	MIL-STD-202, Method 204, Condition D
Shock	MIL-STD-202, Method 213, Condition I

Note: The above characteristics are typical but may not apply to all connectors.

Cable Connectors

Straight Cable Plugs (male)

> for semi-rigid cables

Part No.	Cable Group (Example)	Finish	Remarks	Assembly Instruction
ANO 2111-2060	.047/50 (SMT680-047)	Gold	Solder	AI 01

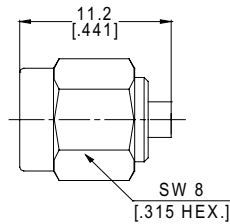

> for semi-rigid cables

Part No.	Cable Group (Example)	Finish	Remarks	Assembly Instruction
ANO 2111-2055	.083/.085/50 (SMT680-086/RG405)	Gold	Solder	AI 01

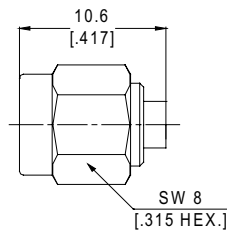

> for semi-rigid cables

Part No.	Cable Group (Example)	Finish	Remarks	Assembly Instruction
ANO 2111-2058	.141/50 (SMT680-141/RG402)	Gold	Solder	AI 01

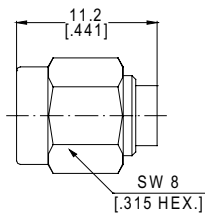

> for flexible cables

Part No.	Cable Group (Example)	Finish	Remarks	Assembly Instruction
ANO 2111-2066	2/50/S (RG178)	Nickel	Solder	AI 02

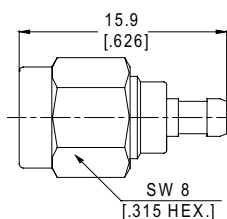

Part No.	Cable Group (Example)	Finish	Remarks	Assembly Instruction
ANO 2111-2028	2.6/50/S/D (RG316/LMR100)	Gold	Crimp	AI 03

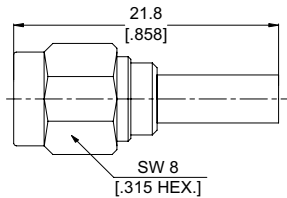

>for flexible cables

Part No.	Cable Group (Example)	Finish	Remarks	Assembly Instruction
ANO 2111-2001	5/50/S/D (RG58/LMR195)	Nickel	Crimp	AI 03

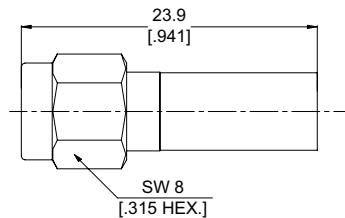

>for flexible cables

Part No.	Cable Group (Example)	Finish	Remarks	Assembly Instruction
ANO 2111-2006	6/50 /D (LMR240)	Albaloy	Crimp	AI 03

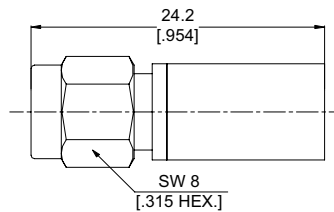

>for flexible cables

Part No.	Cable Group (Example)	Finish	Remarks	Assembly Instruction
ANO 2111-2063	7.5/50 /D (LMR300)	Nickel	Crimp	AI 03

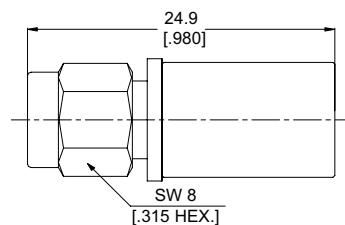

>for flexible cables

Part No.	Cable Group (Example)	Finish	Remarks	Assembly Instruction
ANO 2121-2005	2.6/50/S/D (RG316/LMR100)	Gold	Crimp	AI 05

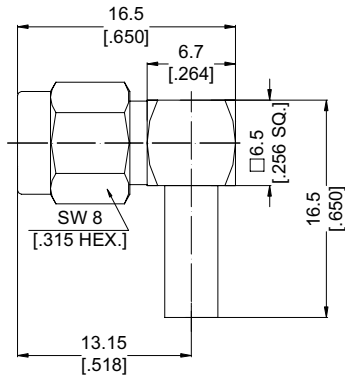

>for flexible cables

Part No.	Cable Group (Example)	Finish	Remarks	Assembly Instruction
ANO 2121-2004	5/50/S/D (RG58/LMR195)	Gold	Crimp	AI 06

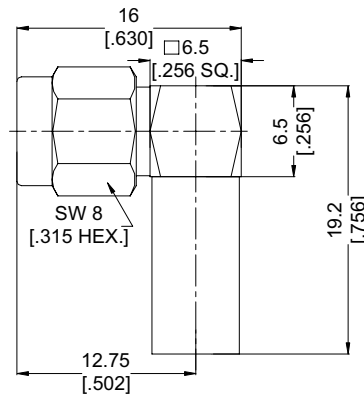

>for flexible cables

Part No.	Cable Group (Example)	Finish	Remarks	Assembly Instruction
ANO 2121-2007	6/50 /D (LMR240)	Albaloy	Crimp	AI 07

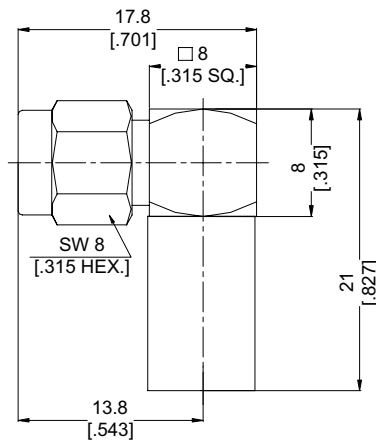

Straight Cable Jacks (female)

> for semi-rigid cables

Part No.	Cable Group (Example)	Finish	Remarks	Assembly Instruction
ANO 2112-2061	.047/50 (SMT680-047)	Gold	Solder	AI 01

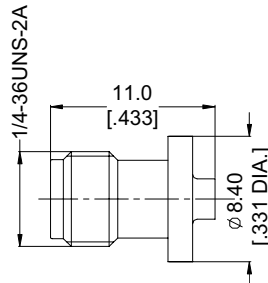

> for semi-rigid cables

Part No.	Cable Group (Example)	Finish	Remarks	Assembly Instruction
ANO 2112-2056	.083/.085/50 (SMT680-086/RG405)	Gold	Solder	AI 01

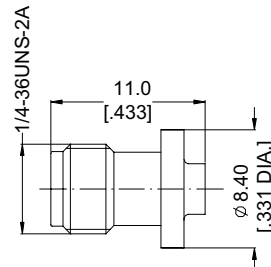

> for semi-rigid cables

Part No.	Cable Group (Example)	Finish	Remarks	Assembly Instruction
ANO 2112-2032	.141/50 (SMT680-141/RG402)	Gold	Solder	AI 01

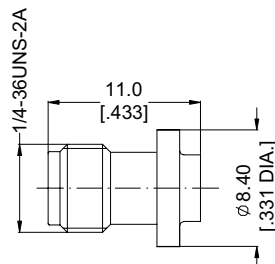

> for flexible cables

Part No.	Cable Group (Example)	Finish	Remarks	Assembly Instruction
ANO 2114-2041	5/50/D (LMR200)	Gold	Crimp	AI 03

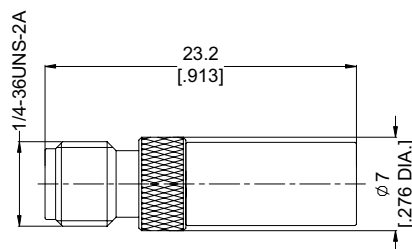

>for flexible cables

Part No.	Cable Group (Example)	Finish	Remarks	Assembly Instruction
ANO 2112-2064	7.5/50 /D (LMR300)	Gold	Crimp	AI 03

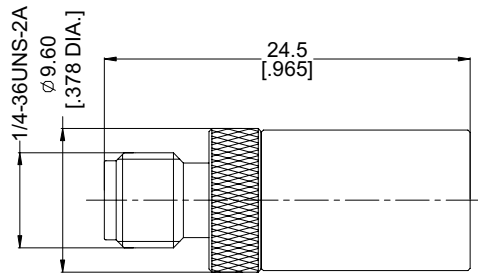

>for flexible cables

Part No.	Cable Group (Example)	Finish	Remarks	Assembly Instruction/Mounting Hole
ANO 2112-1012	2/50/S (RG78)	Gold	Solder	AI 02/MH 3

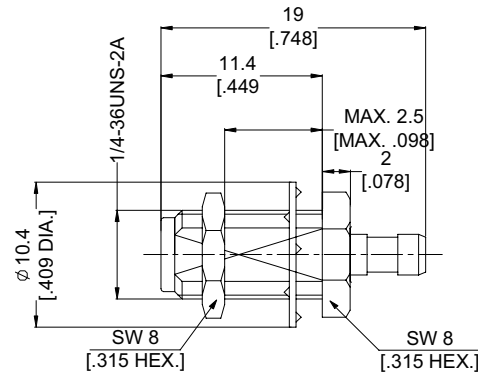

>for flexible cables

Part No.	Cable Group (Example)	Finish	Remarks	Assembly Instruction/Mounting Hole
ANO 2112-1014	2.6/50/S/D (RG316/LMR100)	Gold	Crimp	AI 03/MH 3
ANO 2112-1023	2.6/50/S/D (RG316/LMR100)	Gold	Crimp	AI 03/MH 3

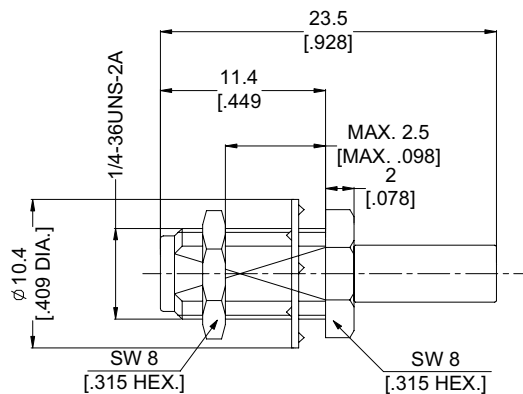

Straight Bulkhead Cable Jacks (female)

>for semi-rigid cables

Part No.	Cable Group (Example)	Finish	Remarks	Assembly Instruction/Mounting Hole
ANO 2112-1062	.047/50 (SMT680-047)	Gold	Solder	AI 01/MH 3

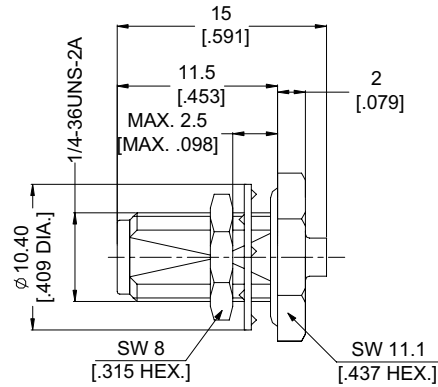

>for semi-rigid cables

Part No.	Cable Group (Example)	Finish	Remarks	Assembly Instruction/Mounting Hole
ANO 2112-1057	.083/.085/50 (SMT680-086/RG405)	Gold	Solder	AI 01/MH 3

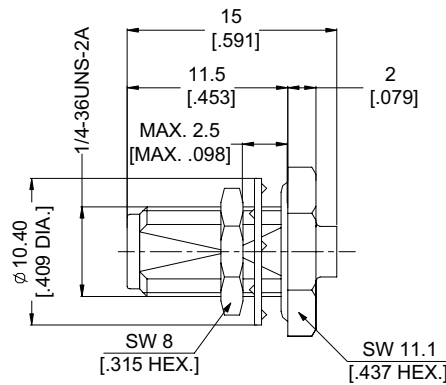

>for semi-rigid cables

Part No.	Cable Group (Example)	Finish	Remarks	Assembly Instruction/Mounting Hole
ANO 2112-1022	.083/.085/50 (RG405)	Gold	Solder	AI 01/MH 3

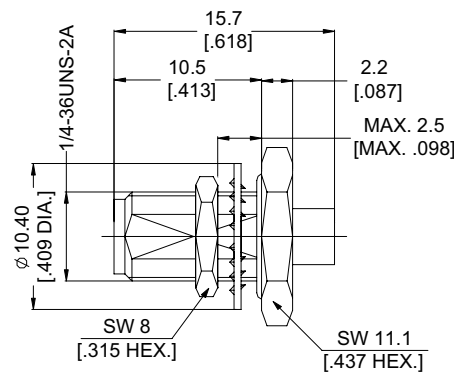

>for semi-rigid cables

Part No.	Cable Group (Example)	Finish	Remarks	Assembly Instruction/Mounting Hole
ANO 2112-1059	.141/50 (SMT680-141/RG402)	Gold	Solder	AI 01/MH 3

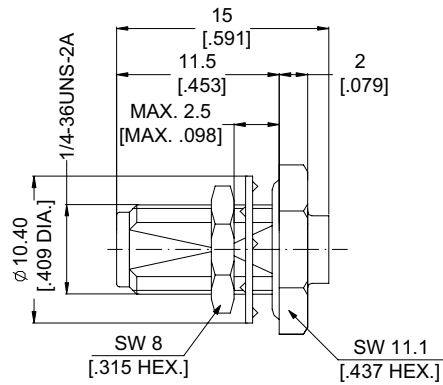

PCB Connectors

Straight PCB jacks (female)

Part No.	Finish	Mounting Hole
ANO 2112-4015	Gold	MH 22

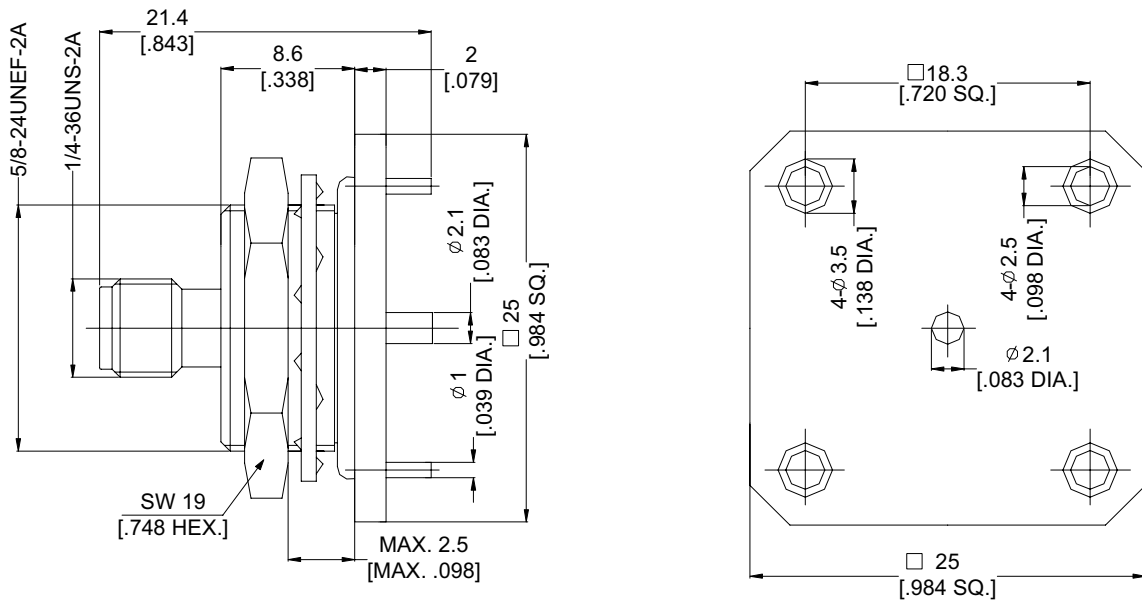

Straight PCB jacks (female)

Part No.	Finish	Mounting Hole
ANO 2112-4019	Gold	MH 16

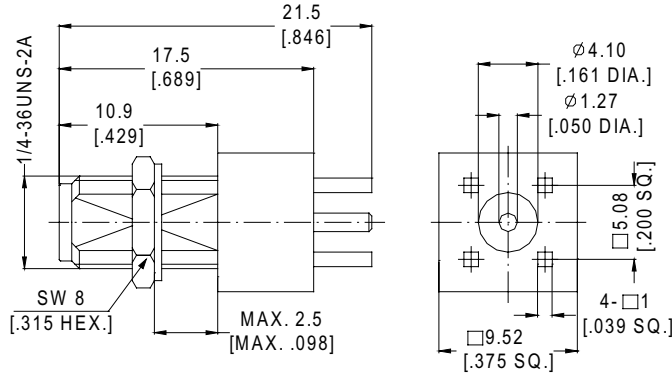

Straight PCB jacks (female)

Part No.	Finish	Mounting Hole
ANO 2112-4034	Gold	MH 3

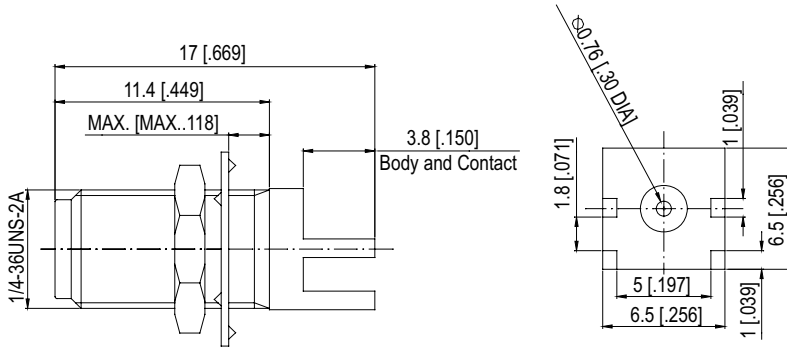

Straight PCB jacks (female)

Part No.	Finish	Fig.
ANO 2112-4016	Gold	1
ANO 2112-4065	Gold	2

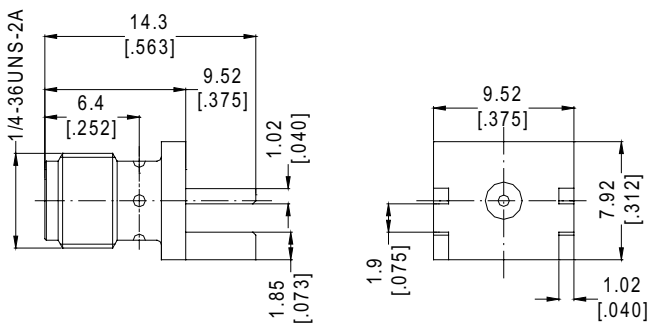

Fig. 1

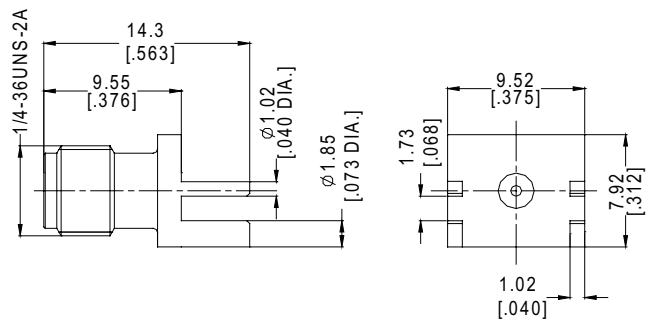
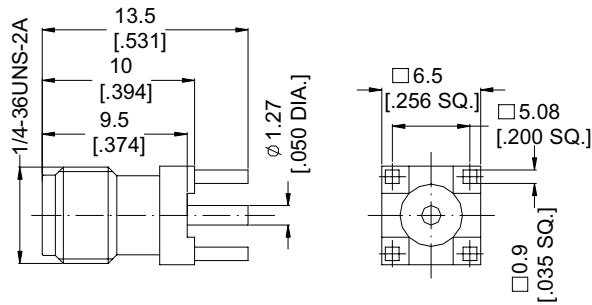

Fig. 2

Straight PCB jacks (female)

Part No.	Finish	Mounting Hole
ANO 2112-4038	Gold	MH 16



Right angle PCB jacks (female)

Part No.	Finish	Mounting Hole
ANO 2122-4049	Gold	MH 21

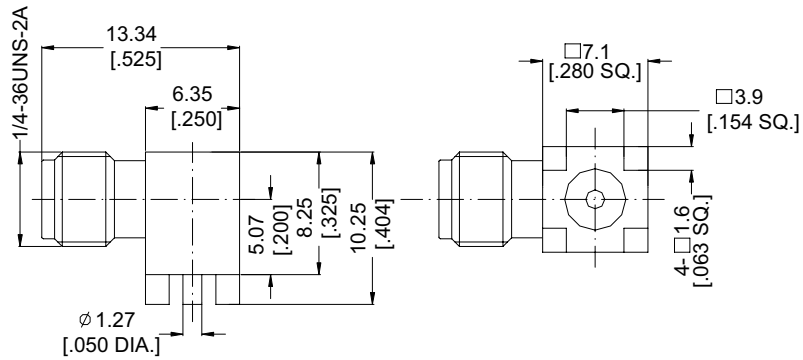

Panel Receptacles

Receptacles, jack (female)

Part No.	Finish	Mounting Hole
ANO 2112-5051	Passivated	MH 2

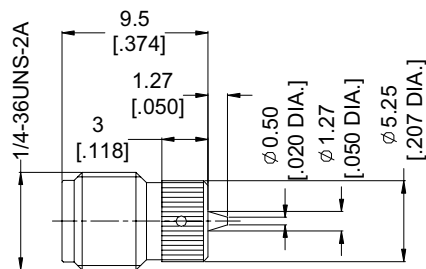

Receptacles, jack (female)

Part No.	Finish	Mounting Hole
ANO 2112-5054	Passivated	MH 3

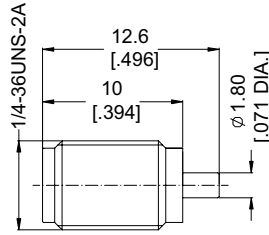

Receptacles, jack (female)

Part No.	Finish	Mounting Hole
ANO 2112-5021	Gold	MH 3

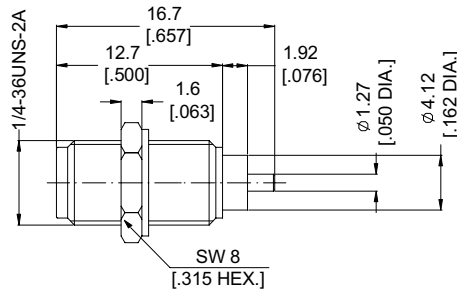

Receptacles, jack (female)

Part No.	Finish	Mounting Hole
ANO 2112-3042	Gold	MH 4

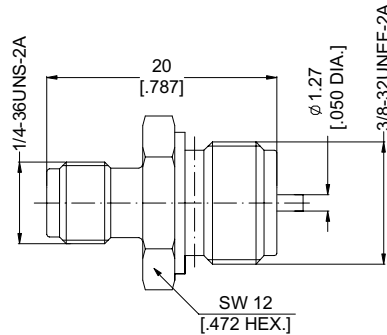

Receptacles, jack (female)

Part No.	Finish	Mounting Hole
ANO 2112-3026	Gold	MH 3

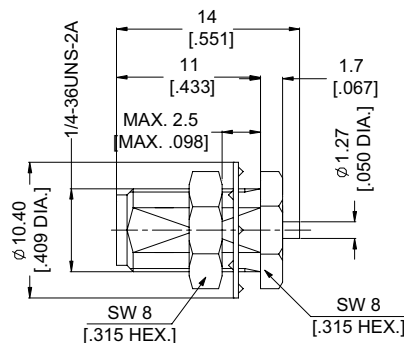

Receptacles, jack (female)

Part No.	Finish	Mounting Hole
ANO 2112-3030	Passivated	MH 6

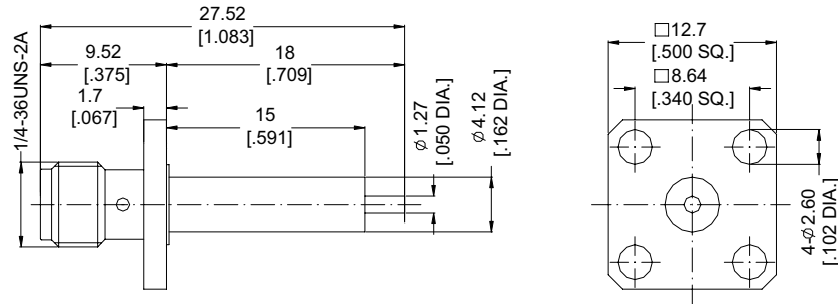

Receptacles, jack (female)

Part No.	Finish	Mounting Hole	Fig.
ANO 2112-3035	Passivated	MH 12	1
ANO 2112-3036	Passivated	MH 10	2

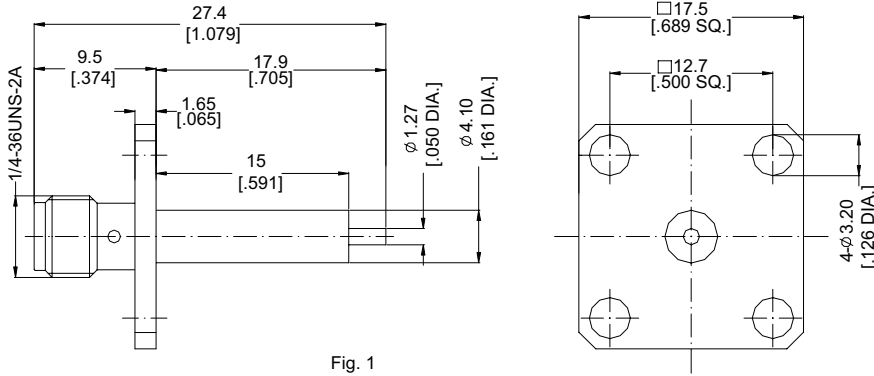

Fig. 1

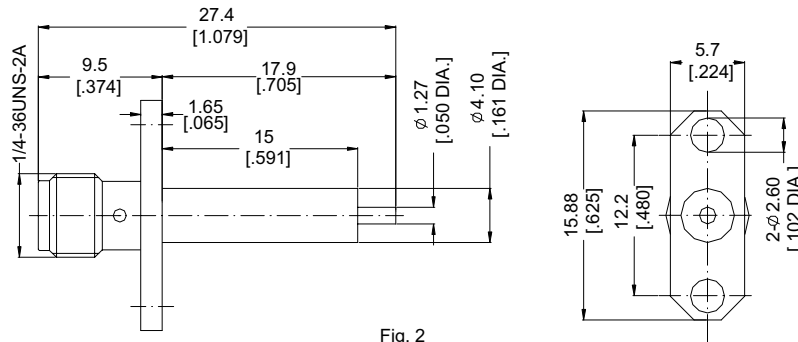
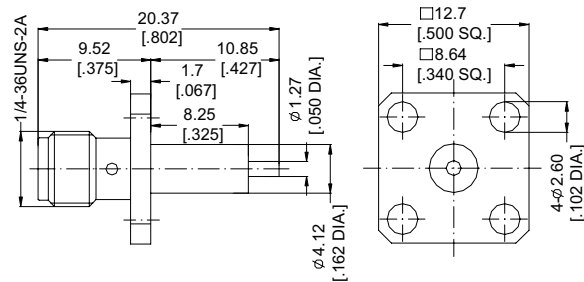

Fig. 2

Receptacles, jack (female)

Part No.	Finish	Mounting Hole
ANO 2112-3020	Gold	MH 6



Receptacles, jack (female)

Part No.	Finish	Mounting Hole
ANO 2112-3045	Gold	MH 14

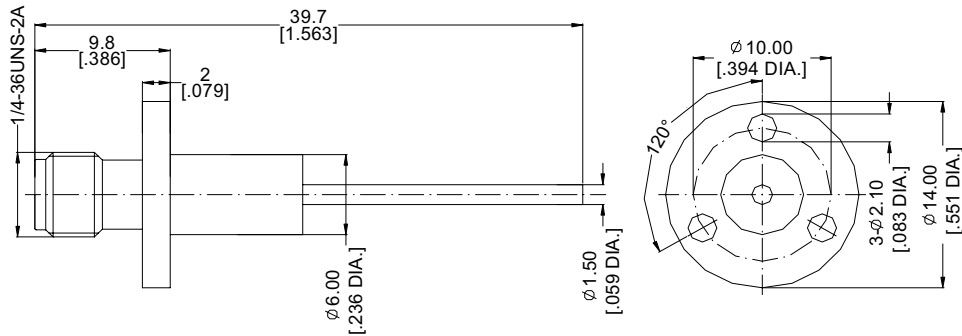

Receptacles, jack (female)

Part No.	Finish	Mounting Hole
ANO 2112-3046	Gold	MH 15

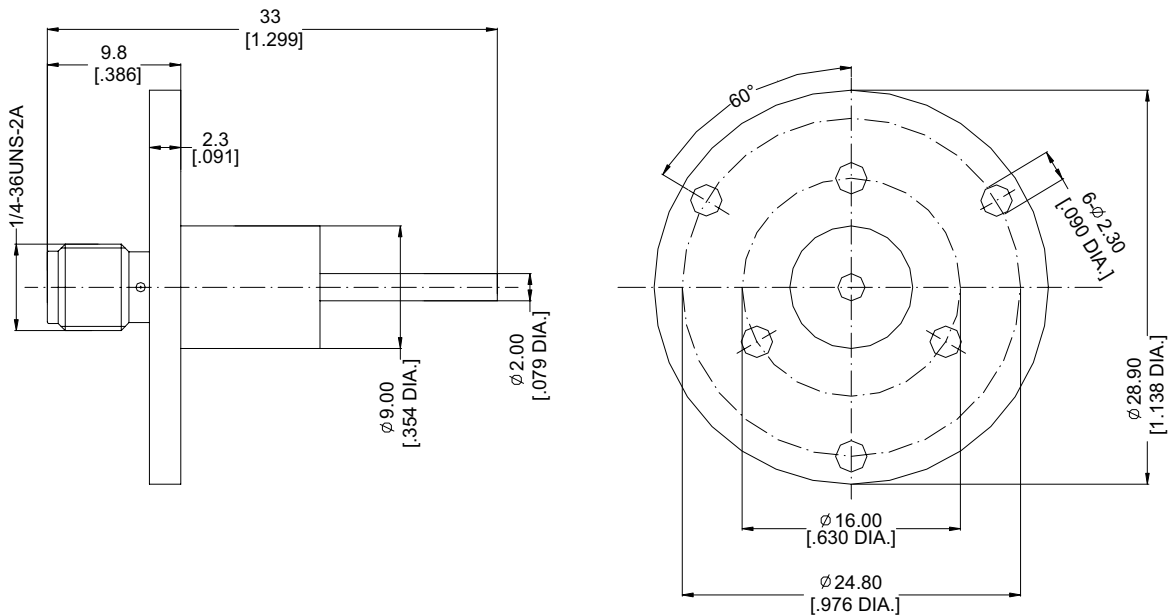

Receptacles, jack (female)

Part No.	Finish	Mounting Hole	Fig.
ANO 2112-3024	Passivated	MH 6	1
ANO 2112-3031	Passivated	MH 10	2

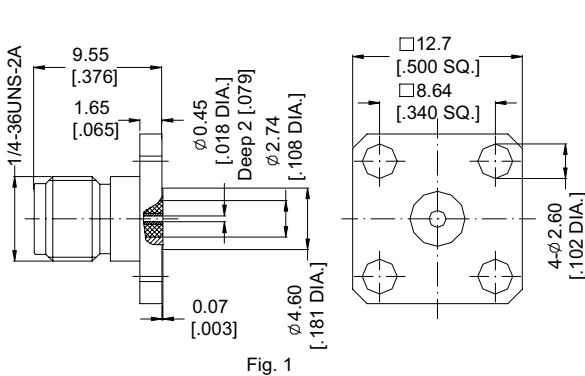

Fig. 1

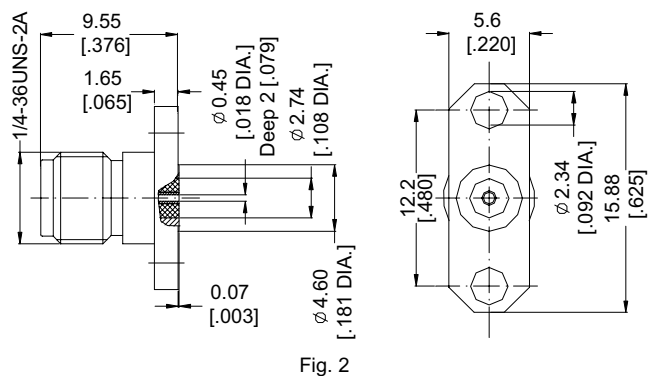
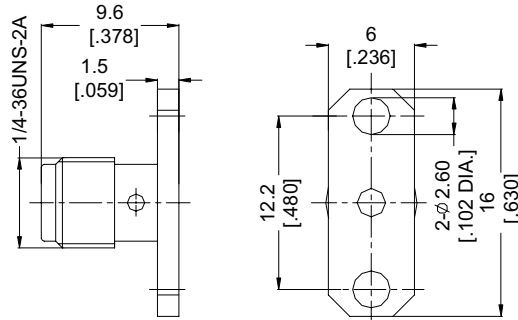

Fig. 2

Receptacles, jack (female)

Part No.	Finish	Mounting Hole
ANO 2112-3068	Gold	MH 10



Flat tab receptacles, jack (female)

Part No.	Finish	Mounting Hole
ANO 2112-3029	Passivated	MH 11

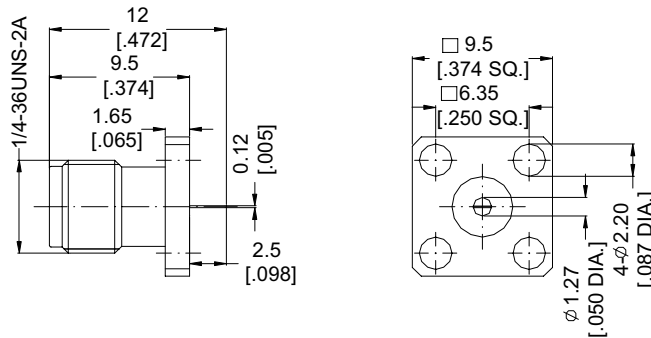

Slot receptacles, jack (female)

Part No.	Finish	Mounting Hole
ANO 2112-3039	Passivated	MH 6

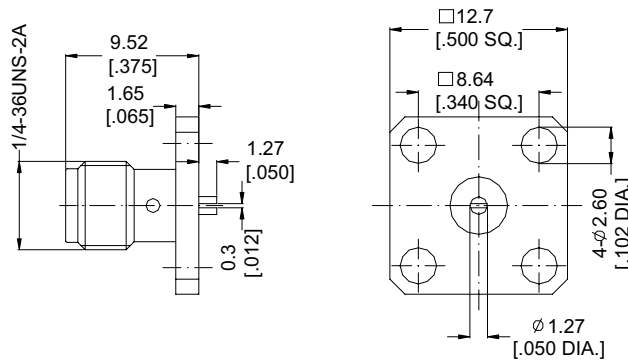

Adapter Connectors

Adapter plug/plug (male/male)

Part No.	Finish	Type / Type
ANO 211-211-1007	Gold	SMA(plug) / SMA(plug)

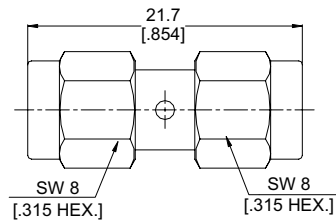

Adapter plug/plug (male/male)

Part No.	Finish	Type / Type
ANO 211-261-1029	Gold/Albaloy	SMA(plug) / QMA(plug)

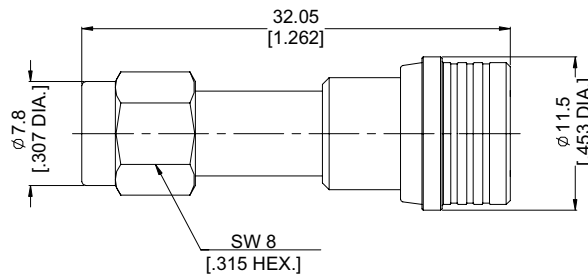

Adapter plug/plug (male/male)

Part No.	Finish	Type / Type
ANO 211-281-1051	Gold/Albaloy	SMA(plug) / Mini-QMA(plug)

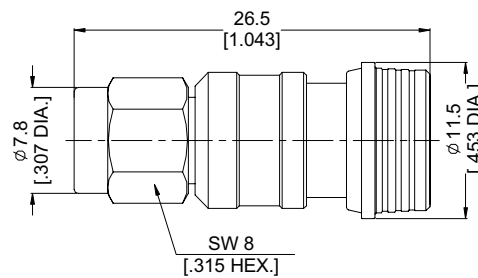

Adapter plug/plug (male/male)

Part No.	Finish	Type / Type
ANO 211-531-1040	Nickel	SMA(plug) / HPQN(plug)

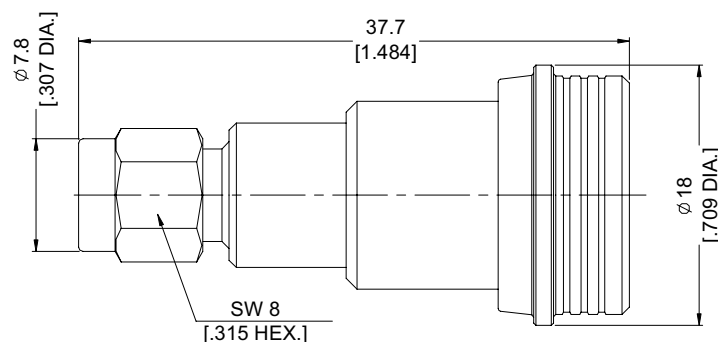

Adapter jack/jack (female/female)

Part No.	Finish	Type / Type
ANO 212-512-1025	Gold	SMA(jack) /SMA(jack)

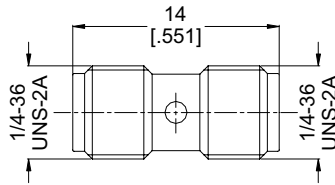

Adapter jack/jack (female/female)

Part No.	Finish	Type / Type
ANO 212-512-1025	Nickel	SMA(jack) / N (jack)

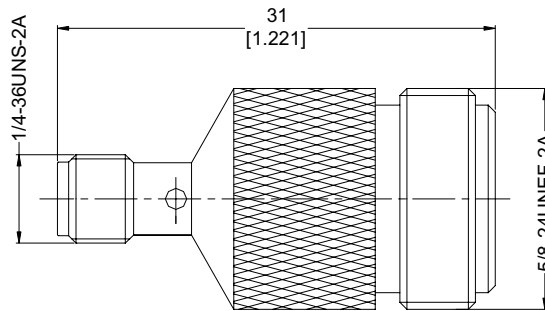

Adapter jack/jack (female/female)

Part No.	Finish	Type / Type
ANO 212-262-1030	Gold/Albaloy	SMA(jack) / QMA (jack)

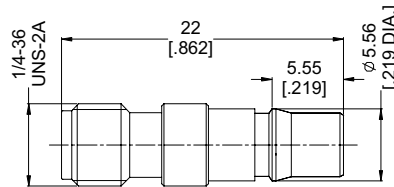

Adapter jack/jack (female/female)

Part No.	Finish	Type / Type
ANO 212-282-1052	Gold/Albaloy	SMA(jack) / Mini-QMA (jack)

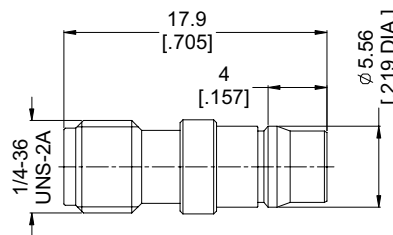

Adapter jack/jack (female/female)

Part No.	Finish	Type / Type
ANO 212-532-1041	Nickel	SMA(jack) / HPQN (jack)

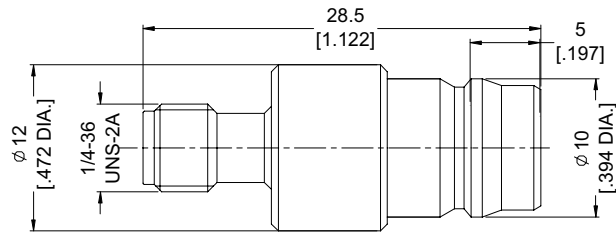

Adapter jack/jack (female/female)

Part No.	Finish	Type / Type	Mounting Hole
ANO 212-212-1004	Gold	SMA(jack) / SMA (jack)	MH 3

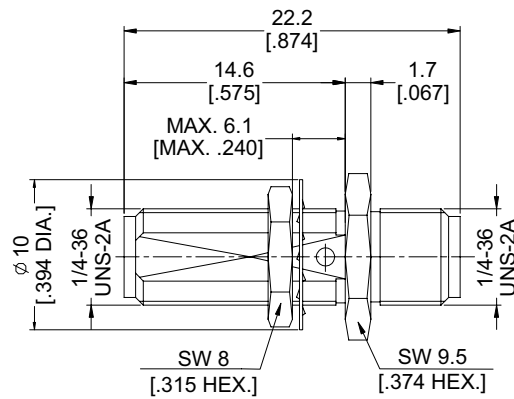

Adapter jack/jack (female/female)

Part No.	Finish	Type / Type	Mounting Hole
ANO 212-214-1005	Gold	SMA(jack) / SMA-RP(jack)	MH 3

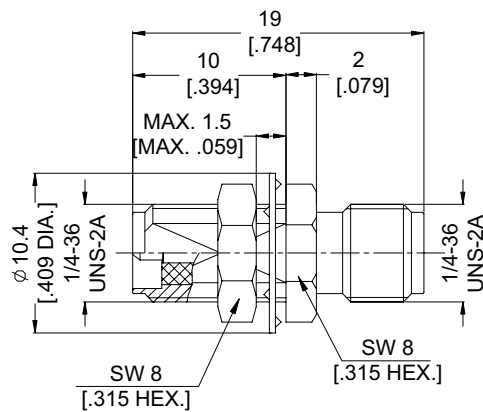

Adapter plug/jack (male/female)

Part No.	Finish	Type / Type
ANO 212-511-1024	Nickel	SMA(jack) / N(plug)

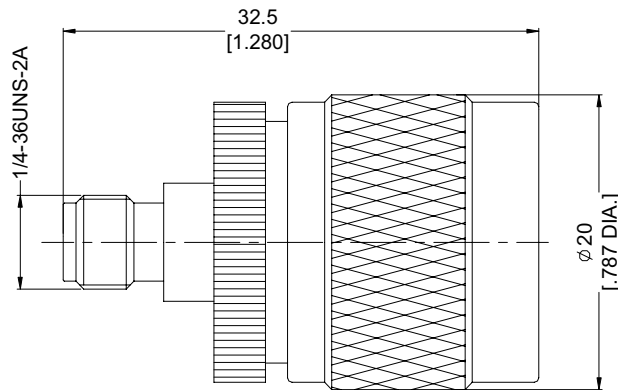

Adapter plug/jack (male/female)

Part No.	Finish	Type / Type
ANO 211-334-1006	Nickel	SMA (plug) / TNC-RP (jack)

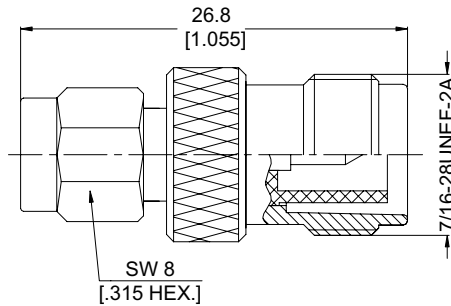

Adapter plug/jack (male/female)

Part No.	Finish	Type / Type
ANO 211-182-1003	Tin	SMA (plug) / UFL (jack)

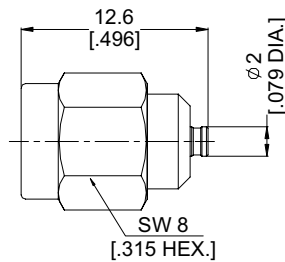

Adapter plug/jack (male/female)

Part No.	Finish	Type / Type
ANO 211-332-1020	Nickel	SMA (plug) / TNC (jack)

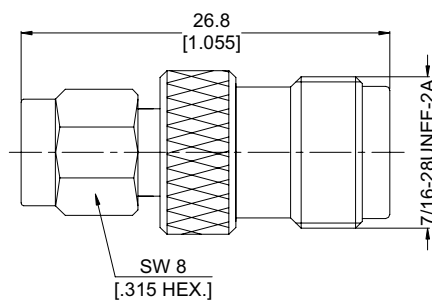

Adapter plug/jack (male/female)

Part No.	Finish	Type / Type
ANO 212-361-1023	Nickel	SMA (jack) / TM (plug)

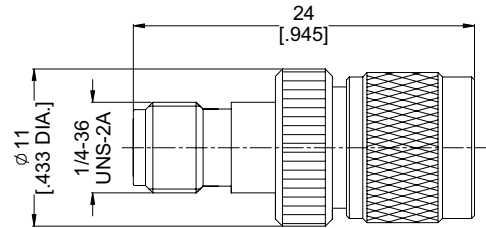

Adapter plug/jack (male/female)

Part No.	Finish	Type / Type
ANO 212-261-1031	Gold/Albaloy	SMA (jack) / QMA (plug)

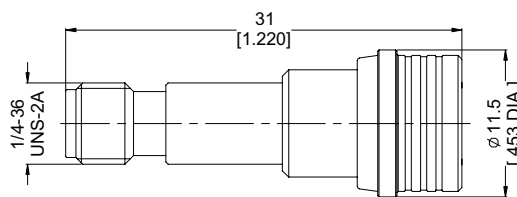

Adapter plug/jack (male/female)

Part No.	Finish	Type / Type
ANO 211-262-1032	Gold/Albaloy	SMA(plug) / QMA (jack)

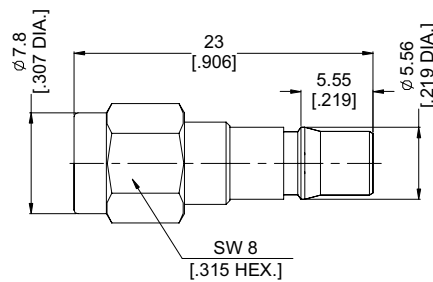

Adapter plug/jack (male/female)

Part No.	Finish	Type / Type
ANO 212-281-1053	Gold/Albaloy	SMA (jack) / Mini-QMA (plug)

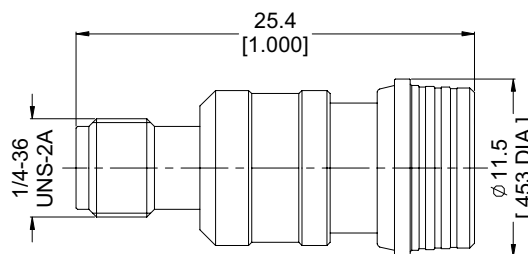

Adapter plug/jack (male/female)

Part No.	Finish	Type / Type
ANO 211-282-1054	Gold/Albaloy	SMA(plug) / Mini-QMA (jack)

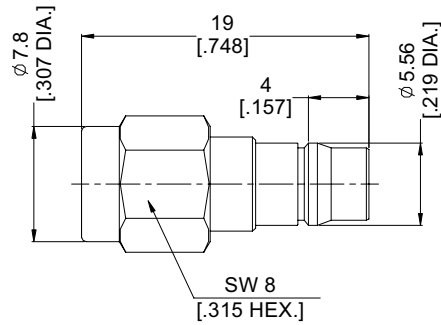

Adapter plug/jack (male/female)

Part No.	Finish	Type / Type
ANO 212-531-1042	Nickel	SMA (jack) / HPQN (plug)

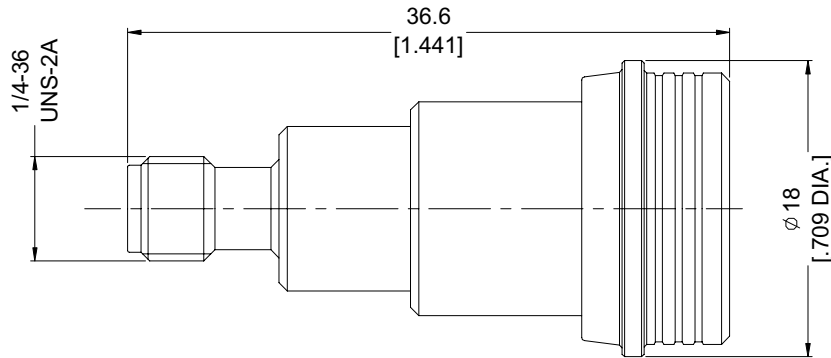

Adapter plug/jack (male/female)

Part No.	Finish	Type / Type
ANO 211-532-1043	Nickel	SMA(plug) / HPQN (jack)

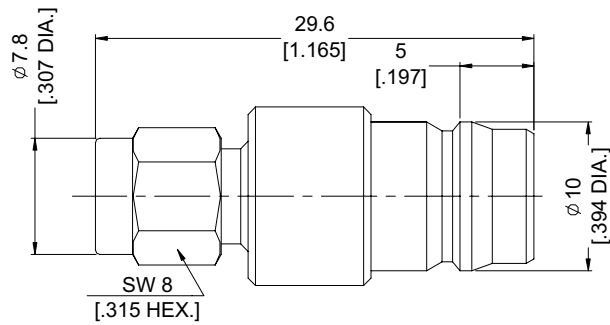

Termination

Straight Plug (male)

Part No.	Finish	Average Power	Peak Power	Frequency
ANO 211-702	Nickel	1W	500W	0-18 GHz

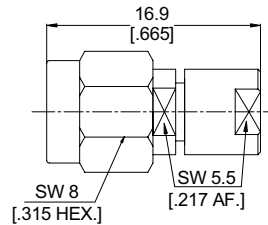

Straight Plug (male)

Part No.	Finish	Average Power	Peak Power	Frequency
ANO 211-703	Nickel	2W	500W	0-18 GHz

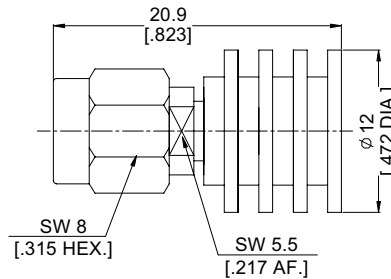

Straight Jack (female)

Part No.	Finish	Average Power	Peak Power	Frequency
ANO 212-701	Nickel	2W	500W	0-6 GHz

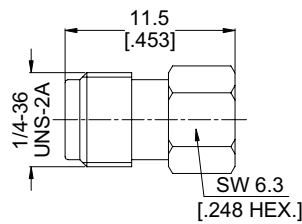

Assembly Instruction

AI 01

Part No.	Cable Group (Example)	Stripping Length a
ANO 2111-2060	.047/50 (SMT680-047)	2.5
ANO 2112-2061		
ANO 2112-1062		
ANO 2112-1057	.083/.085/50 (SMT680-086/RG405)	2.5
ANO 2112-2056		
ANO 2111-2055		3.0
ANO 2112-1022		
ANO 2111-2058	.141/50 (SMT680-141/RG402)	3.0
ANO 2111-2067		2.2
ANO 2112-2032		2.5
ANO 2112-1059		

①

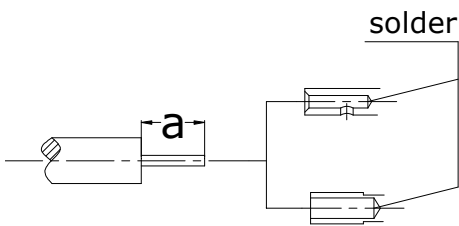

- 1.1 Strip the cable.
- 1.2 Slide on center contact until it bottoms against cable dielectric.
- 1.3 Solder center contact.
- 1.4 Clean soldering area.

②

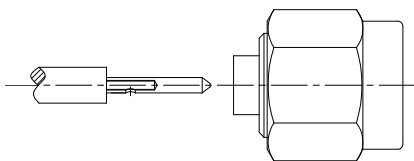

- 2.1 Slide the cable into the body until it bottoms against insulator.

③

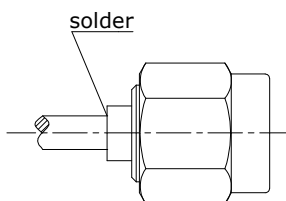

- 3.1 Solder the body onto the cable.
- 3.2 Clean soldering area.

AI 02

Part No.	Cable Group (Example)	Stripping Length		
		a	b	c
ANO 2111-2066	2/50/S (RG78)	2.0	2.0	5.0
ANO 2112-1012		3.0	1.5	8.1

①

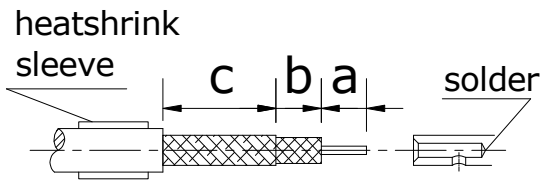

- 1.1 Slide onto the cable the heatshrink sleeve.
- 1.2 Strip the cable.
- 1.3 Slide on center contact until it bottoms against cable dielectrique.
- 1.4 Solder center contact.

②

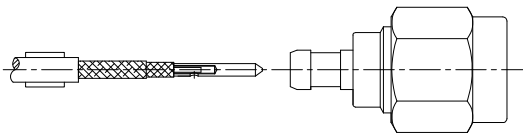

- 2.1 Slide the cable into the body until it bottoms against insulator.

③

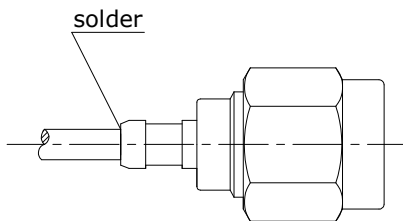

- 3.1 Solder the body onto the cable.
- 3.2 Clean soldering area.

④

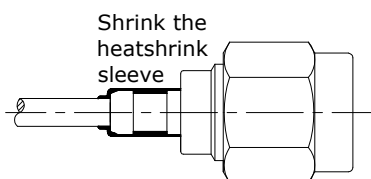

- 4.1 Slide sleeve over soldering area and heatshrink in place.

AI 03

Part No.	Cable Group (Example)	Stripping Length		
		a	b	c
ANO 2111-2028	2.6/50/S/D (RG316/LMR100)	2.5	2.5	5.5
ANO 2111-2008		2.0	2.0	6.0
ANO 2111-2001	5/50/S/D (RG58/LMR195)	2.5	7.5	8.0
ANO 2111-2006	6/50 /D (LMR240)	2.5	5.7	8.0
ANO 2111-2063	7.5/50 /D (LMR300)	3.0	1.0	6.0
ANO 2112-2064				
ANO 2111-2003	10.5/50 /D (LMR400)	4.0	7.5	10.5
ANO 2111-2050	5/50/D (RG142)	4.0	0	7.0
ANO 2114-2041	5/50/D (LMR200)	2.3	7.2	8.0
ANO 2112-1014	2.6/50/S/D (RG316/LMR100)	3.0	2.8	6.0
ANO 2112-1023		3.0	1.9	6.0

①

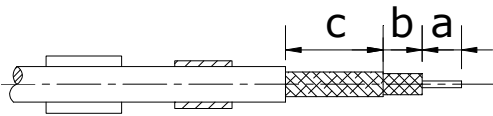

②

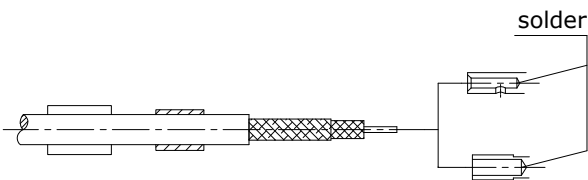

③

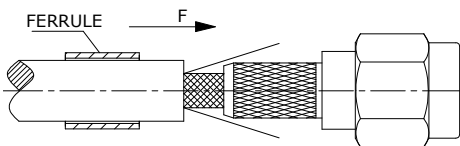

④

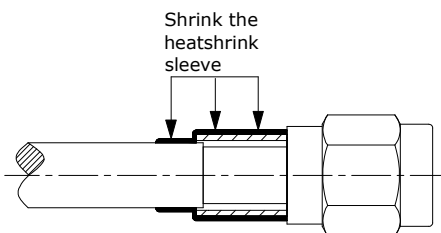

- 1.1 Slide onto the cable the heatshrink sleeve and the ferrule.
- 1.2 Strip the cable.

- 2.1 Slide on center contact until it bottoms against cable dielectrique.
- 2.2 Solder center contact.
- 2.3 Clean soldering area.

- 3.1 Fan the braid.
- 3.2 Slide the cable into the body until it bottoms against insulator.
- 3.3 Slide the ferrule over the braid.
(In direction F)

- 4.1 Cut the excess of braid.
- 4.2 Crimp the ferrule.
- 4.3 Slide sleeve over ferrule and heatshrink in place.

AI 04

Part No.	Cable Group (Example)	Stripping Length		
		a	b	c
ANO 2121-2002	2/50/S (RG178)	1.0	2.0	6.2

①

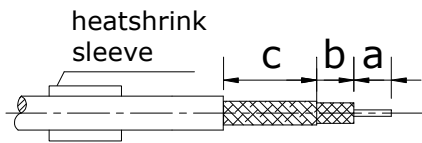

- 1.1 Slide onto the cable the heatshrink sleeve.
- 1.2 Strip the cable.

②

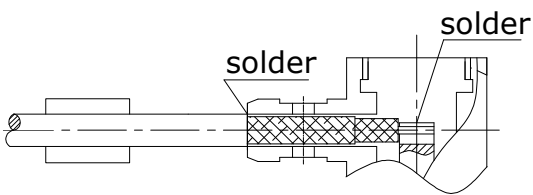

- 2.1 Slide the cable into the body
- 2.2 solder inner conductor.
- 2.3 Solder the body onto the cable.

③

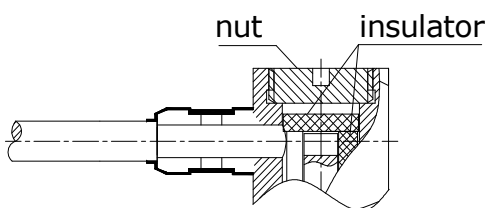

- 3.1 Slide sleeve over soldering area and heatshrink in place.
- 3.2 Mount the insulator.
- 3.3 screw the nut into the body.

AI 05

Part No.	Cable Group (Example)	Stripping Length		
		a	b	c
ANO 2121-2005	2.6/50/S/D (RG316/LMR100)	1.0	2.2	6.0

①

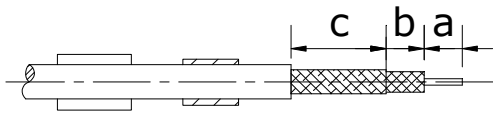

- 1.1 Slide onto the cable the heatshrink sleeve and the ferrule.
- 1.2 Strip the cable.

②

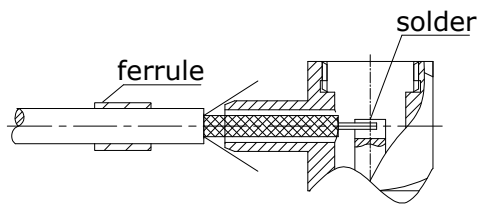

- 2.1 Fan the braid.
- 2.2 Push connector body under the braid.
- 2.3 Solder inner conductor.
- 2.4 Slide the ferrule over the braid.

③

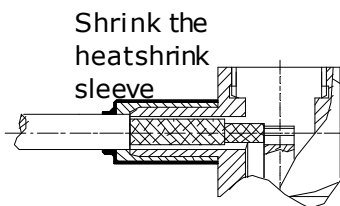

- 3.1 Cut the excess of braid.
- 3.2 Crimp the ferrule.
- 3.3 Slide sleeve over ferrule and heatshrink in place.

④

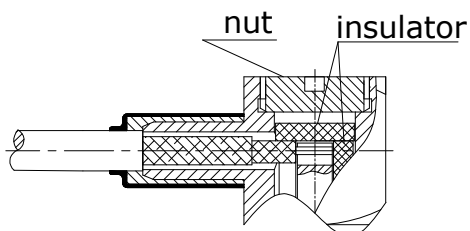

- 4.1 Mount the insulator.
- 4.2 Screw the nut into the body

AI 06

Part No.	Cable Group (Example)	Stripping Length		
		a	b	c
ANO 2121-2004	5/50/S/D (R58/LMR195)	1.7	3.6	7.7

①

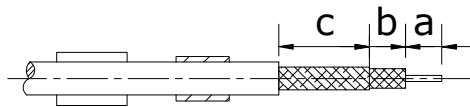

- 1.1 Slide onto the cable the heatshrink sleeve and the ferrule.
- 1.2 Strip the cable.

②

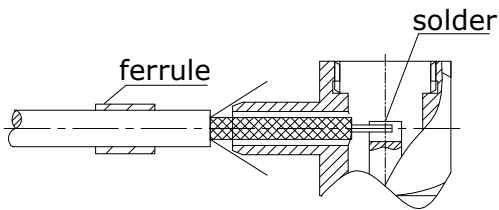

- 2.1 Fan the braid.
- 2.2 Push connector body under the braid.
- 2.3 Solder inner conductor.
- 2.4 Slide the ferrule over the braid.

③

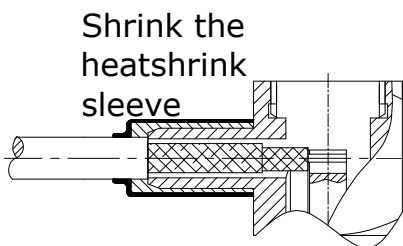

- 3.1 Cut the excess of braid.
- 3.2 Crimp the ferrule.
- 3.3 Slide sleeve over ferrule and heatshrink in place.

④

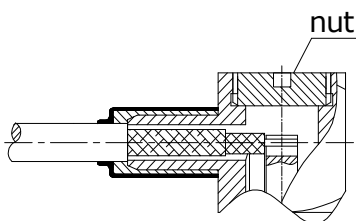

- 4.1 Screw the nut into the body

AI 07

Part No.	Cable Group (Example)	Stripping Length		
		a	b	c
ANO 2121-2007	6/50 /D (LMR240)	2.5	3.0	8.0

①

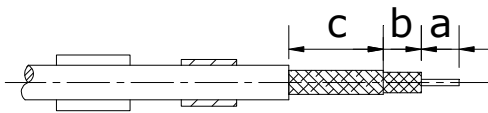

- 1.1 Slide onto the cable the heatshrink sleeve and the ferrule.
- 1.2 Strip the cable.

②

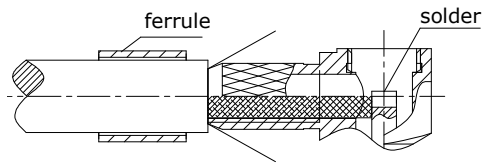

- 2.1 Fan the braid.
- 2.2 Push connector body under the braid.
- 2.3 solder inner conductor.
- 2.4 Slide the ferrule over the braid.

③

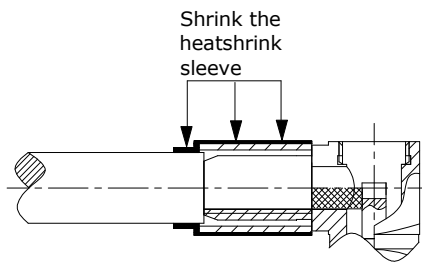

- 3.1 Cut the excess of braid.
- 3.2 Crimp the ferrule.
- 3.3 Slide sleeve over ferrule and heatshrink in place.

④

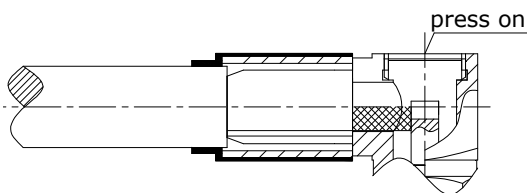

- 4.1 Place the cap.
- 4.2 Press cap flush or slightly below surface of body assembly.