

4 3 2 1

MATERIAL & FINISH:

- 1 BODY: STAINLESS STEEL, PASSIVATED
- 2 CENTER CONTACT: BERYLLIUM COPPER ALLOY, GOLD PLATED
- 3 INSULATOR: PTFE & PEI

ELECTRICAL DATA:

- 1 IMPEDANCE: 50 Ω
- 2 FREQUENCY RANGE: DC~40 GHz
- 3 VSWR: ≤1.20

ENVIRONMENTAL DATA:

- 1 TEMPERATURE RANGE: -55°C~+125°C
- 2 2011/65/EU(RoHS) AND 2015/863/(RoHS): COMPLIANT
- 3 1907/2006/EC(REACH): COMPLIANT

REVISIONS			
REV.	DESCRIPTION	DATE	APPROVED
A	INITIAL RELEASE	06/21/22	J. Q
B	DRAWING CHANGED	04/20/23	J. Q

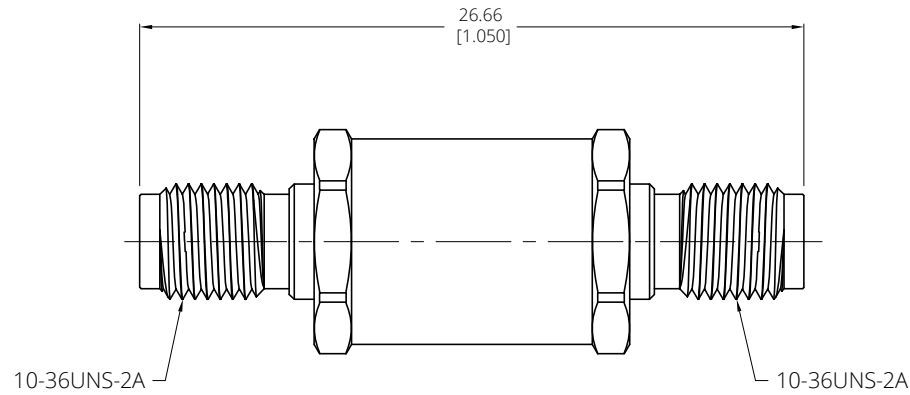

DRAWN	W. Y	DATE	04/20/23
CHECKED	X. Y	DATE	04/20/23
APPROVED	J. Q	DATE	04/20/23
UNLESS OTHERWISE SPECIFIED DIMENSIONS ARE IN MILLIMETERS, DIMENSIONS IN [] ARE IN INCHES FOR CUSTOMER REFERENCE ONLY UNLESS OTHERWISE SPECIFIED TOLERANCE ARE:		THESE DRAWINGS AND SPECIFICATIONS ARE THE PROPERTY OF ANOISON ELECTRONICS LTD AND SHOULD NOT BE USED WITHOUT WRITTEN PERMISSION COPYRIGHT © 2023 ANOISON ELECTRONICS LTD	
	XX	±0.13 [005"]	
	X	±0.20 [008"]	
	x	±0.50 [019"]	
	X°	±1°	
	x°	±2°	



TITLE			
PRECISION ADAPTER, SSMA FEMALE TO SSMA FEMALE			
VIEW	PART NO. PA9191C		
		SIZE A3	SCALE 5:1
		SHEET 1/1	REV. B

4 3 2 1