

MATERIAL & FINISH:

1. BODY: STAINLESS STEEL, PASSIVATED
2. CENTER CONTACT: BERYLLIUM COPPER ALLOY, GOLD PLATED

ENVIRONMENTAL DATA:

1. STORAGE TEMPERATURE: -55°C~+125°C
2. OPERATING TEMPERATURE: 0°C~+85°C
3. 2011/65/EU (RoHS): COMPLIANT

ELECTRICAL DATA:

1. IMPEDANCE: 50 Ω
2. FREQUENCY RANGE: DC~26.5 GHz
3. VSWR: 1.15 MAX.
4. INSERTION LOSS: 0.25 DB MAX.

MECHANICAL DATA:

1. MECHANICAL DURABILITY: 2000 CYCLES MIN.
2. RECOMMENDED TORQUE:
 NMD2.4MM FEMALE: 1.35~2 NM
 3.5MM FEMALE: 0.9 NM

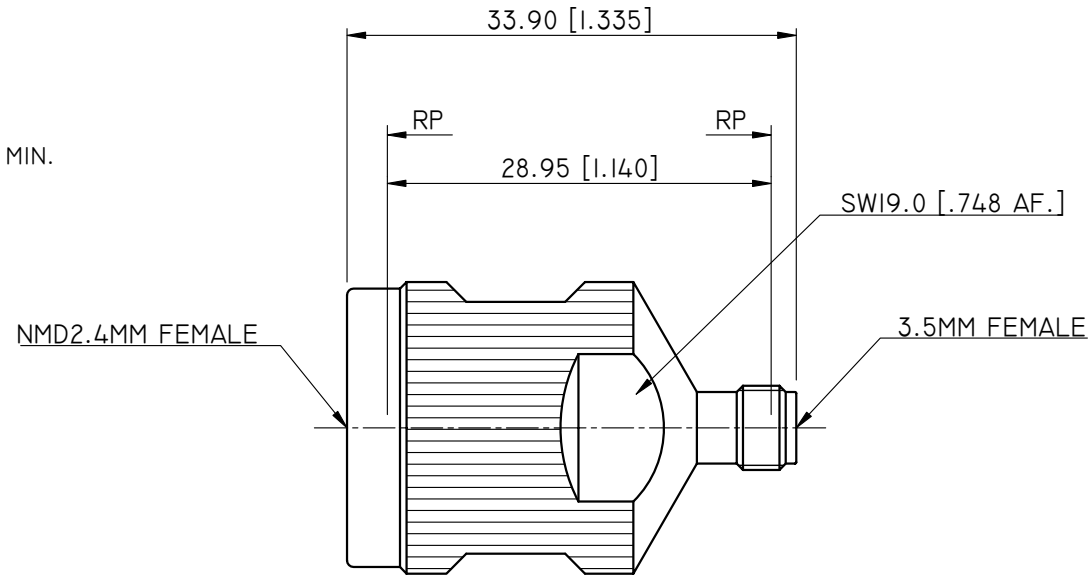

REVISIONS			
REV.	DESCRIPTION	DATE	APPROVED
A	INITIAL RELEASE	05/14/15	J. QU

DRAWN X. B. YANG	DATE 05/14/15		
CHECKED L. YANG	DATE 05/14/15		
APPROVED J. QU	DATE 05/14/15		
UNLESS OTHERWISE SPECIFIED DIMENSIONS ARE IN MILLIMETERS, DIMENSIONS IN [] ARE IN INCHES FOR CUSTOMER REFERENCE ONLY UNLESS OTHERWISE SPECIFIED TOLERANCE ARE: .XX ±0.13 [.005"] .X ±0.20 [.008"] X ±0.50 [.019"] .X° ±1° X° ±2°		THESE DRAWINGS AND SPECIFICATIONS ARE THE PROPERTY OF ANOISON ELECTRONICS LTD AND SHOULD NOT BE USED WITHOUT WRITTEN PERMISSION COPYRIGHT © 2015 ANOISON ELECTRONICS LTD	
TITLE ADAPTER, NMD2.4MM FEMALE TO 3.5MM FEMALE		VIEW 	PART NO. PA6825C
SIZE A3	SCALE 2.5:1	SHEET 1/1	REV. A