

4

3

2

1

MATERIAL & FINISH:

1. BODY: STAINLESS STEEL, PASSIVATED
2. CENTER CONTACT: BERYLLIUM COPPER ALLOY, GOLD PLATED
3. INSULATOR: PEI

ENVIRONMENTAL DATA:

1. STORAGE TEMPERATURE: -55°C~+125°C
2. OPERATING TEMPERATURE: 0°C~+85°C
3. 2011/65/EU (RoHS): COMPLIANT

ELECTRICAL DATA:

1. IMPEDANCE: 50 Ω
2. FREQUENCY RANGE: DC~40 GHZ
3. VSWR: 1.20 TYP.
4. INSERTION LOSS: 0.36 DB MAX.

MECHANICAL DATA:

1. MECHANICAL DURABILITY: 2000 CYCLES MIN.
2. RECOMMENDED TORQUE:
 - NMD2.92MM FEMALE: 1.35~2 NM
 - 2.4MM FEMALE: 0.9 NM

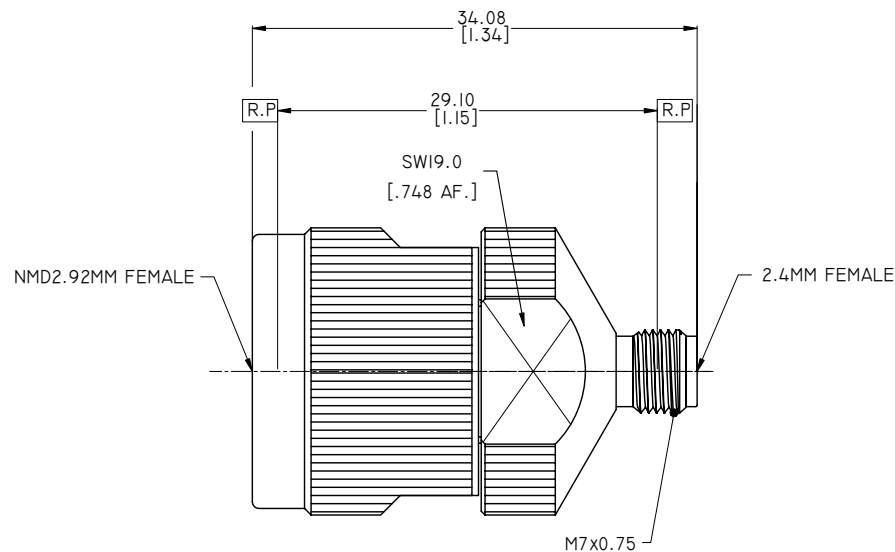

REVISIONS			
REV.	DESCRIPTION	DATE	APPROVED
A	INITIAL RELEASE	12/28/17	J. QU

DRAWN	P. CHEN	DATE	12/28/17
CHECKED	X. B. YANG	DATE	12/28/17
APPROVED	J. QU	DATE	12/28/17

UNLESS OTHERWISE SPECIFIED DIMENSIONS ARE IN MILLIMETERS, DIMENSIONS IN [] ARE IN INCHES FOR CUSTOMER REFERENCE ONLY UNLESS OTHERWISE SPECIFIED TOLERANCE ARE:

.XX	±0.13 [0.005"]
.X	±0.20 [0.008"]
X	±0.50 [0.019"]
.X°	±1°
X°	±2°

THESE DRAWINGS AND SPECIFICATIONS ARE THE PROPERTY OF ANOISON ELECTRONICS LTD AND SHOULD NOT BE USED WITHOUT WRITTEN PERMISSION COPYRIGHT © 2017 ANOISON ELECTRONICS LTD



TITLE
PRECISION ADAPTER, NMD2.92MM FEMALE TO 2.4MM FEMALE

VIEW

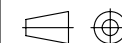

PART NO.

PA6422C

SIZE
A3SCALE
2.5:1SHEET
1/1REV.
A

4

3

2

1