

4

3

2

1

MATERIAL & FINISH:

- 1 BODY : STAINLESS STEEL, PASSIVATED
- 2 CENTER CONTACT: BERYLLIUM COPPER ALLOY, GOLD PLATED
- 3 INSULATOR: PEI
- 4 CLAMP NUT: STAINLESS STEEL, PASSIVATED
- 5 LOCK WASHER: PHOSPHOR BRONZE, PASSIVATED

ELECTRICAL DATA:

- 1 IMPEDANCE: 50 Ω
- 2 FREQUENCY RANGE: DC~67 GHz
- 3 VSWR: 1.25 MAX.

ENVIRONMENTAL DATA:

- 1 TEMPERATURE RANGE: -55 °C~+125 °C
- 2 2011/65/EU(RoHS) AND 2015/863/(RoHS): COMPLIANT
- 3 1999/45/EC(REACH): COMPLIANT

REVISIONS			
REV.	DESCRIPTION	DATE	APPROVED
A	INITIAL RELEASE	01/19/21	J QU

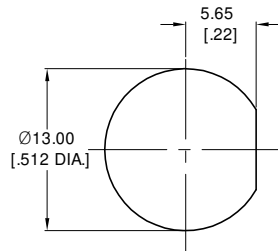

RECOMMENDED MOUNTING HOLE

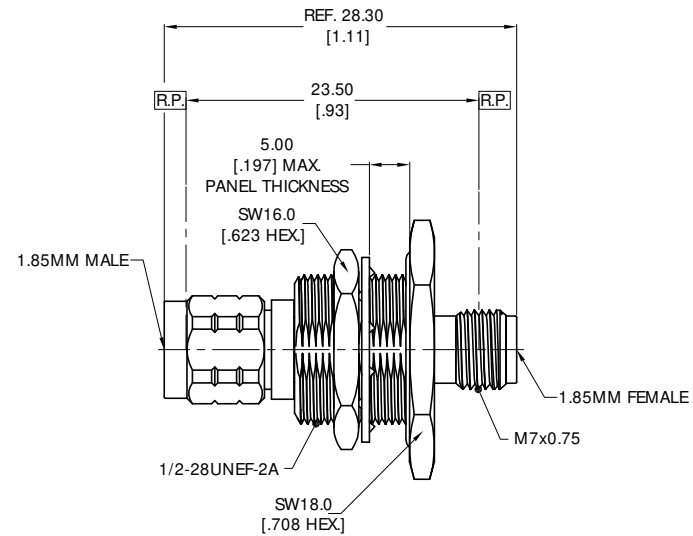

DRAWN	P. CHEN	DATE	01/19/21
CHECKED	X. B. YANG	DATE	01/19/21
APPROVED	J QU	DATE	01/19/21
UNLESS OTHERWISE SPECIFIED DIMENSIONS ARE IN MILLIMETERS, DIMENSIONS IN [] ARE IN INCHES FOR CUSTOMER REFERENCE ONLY UNLESS OTHERWISE SPECIFIED TOLERANCE ARE:		THESE DRAWINGS AND SPECIFICATIONS ARE THE PROPERTY OF ANOISON ELECTRONICS LTD AND SHOULD NOT BE USED WITHOUT WRITTEN PERMISSION COPYRIGHT © 2021 ANOISON ELECTRONICS LTD	
.XX	±0.13 [.005"]		
.X	±0.20 [.008"]		
X	±0.50 [.019"]		
.X°	±1°		
X°	±2°		



TITLE			
PRECISION ADAPTER 1.85MM BULKHEAD MALE TO 1.85MM FEMALE			
VIEW		PART NO.	
		PA6262S	
SIZE	SCALE	SHEET	REV.
A3	2.5:1	1/1	A

4

3

2

1