

REVISIONS			
REV.	DESCRIPTION	DATE	APPROVED
A	INITIAL RELEASE	09/18/15	J. QU

1.0 MATERIAL & FINISH

- 1.1 BODY: STAINLESS STEEL, PASSIVATED
- 1.2 CENTER CONTACT: BERYLLIUM BRONZE, GOLD PLATED
- 1.3 INSULATOR: PTFE & PEI
- 1.4 COUPLING NUT: STAINLESS STEEL, PASSIVATED

3.0 ELECTRICAL SPECIFICATIONS:

- 3.1 IMPEDANCE: 50 Ω
- 3.2 FREQUENCY RANGE: DC~18GHZ
- 3.3 VSWR: 1.20 MAX.

2.0 ENVIRONMENTAL DATA:

- 2.1 TEMPERATURE RANGE: -55°C~+125°C
- 2.2 2011/65/EU (RoHS): COMPLIANT

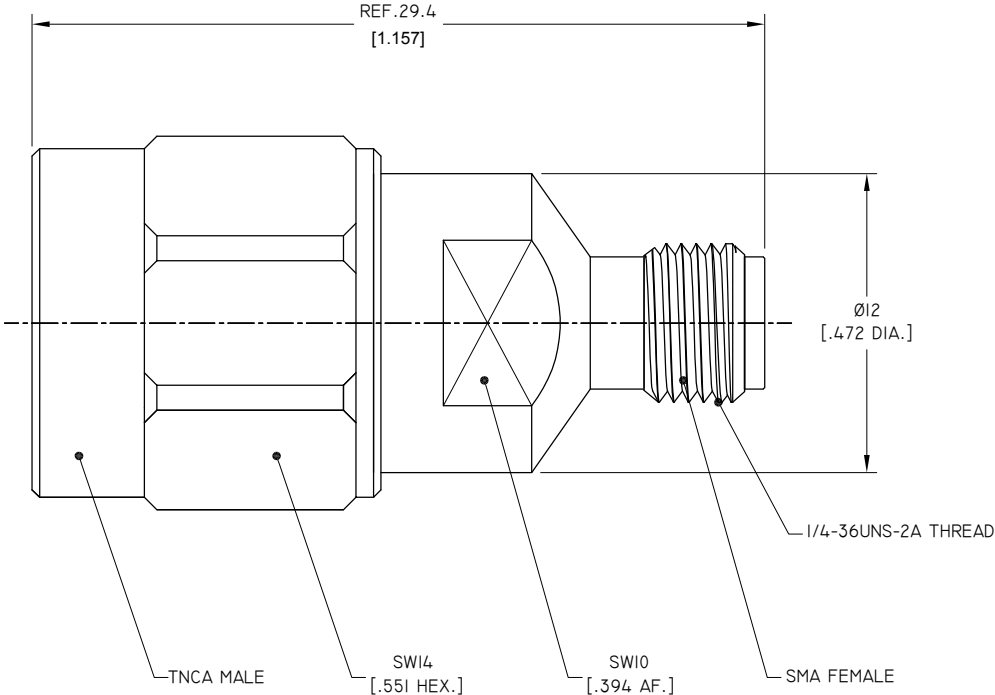

DRAWN	P. CHEN	DATE	09/18/15
CHECKED	L. YANG	DATE	09/18/15
APPROVED	J. QU	DATE	09/18/15
UNLESS OTHERWISE SPECIFIED DIMENSIONS ARE IN MILLIMETERS, DIMENSIONS IN [] ARE IN INCHES FOR CUSTOMER REFERENCE ONLY UNLESS OTHERWISE SPECIFIED TOLERANCE ARE:		THESE DRAWINGS AND SPECIFICATIONS ARE THE PROPERTY OF ANOISON ELECTRONICS LTD AND SHOULD NOT BE USED WITHOUT WRITTEN PERMISSION COPYRIGHT © 2015 ANOISON ELECTRONICS LTD	
.XX	±0.13 [.005"]		
.X	±0.20 [.008"]		
X	±0.50 [.019"]		
X°	±1°		
X"	±2°		

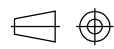

TITLE
ADAPTER, TNCA MALE TO SMA FEMALE

VIEW 

PART NO. PA3021B

SIZE	SCALE	SHEET	REV.
A3	5:1	1/1	A