

REVISIONS			
REV.	DESCRIPTION	DATE	APPROVED
A	INITIAL RELEASE	05/29/15	J. QU

**MATERIAL & FINISH:**

1. BODY: STAINLESS STEEL, PASSIVATED
2. CENTER CONTACT: BERYLLIUM COPPER ALLOY, GOLD PLATED
3. FASTENING NUT: STAINLESS STEEL, PASSIVATED
4. WASHER: PHOSPHOR BRONZE
5. INSULATOR: MPP0/PEI

**ENVIRONMENTAL DATA:**

1. TEMPERATURE RANGE: -55°C~+125°C
2. 2002/95/EC (RoHS): COMPLIANT

**ELECTRICAL SPECIFICATIONS:**

1. IMPEDANCE: 50 Ω
2. FREQUENCY RANGE: DC~33GHZ
3. VSWR: 1.15 MAX

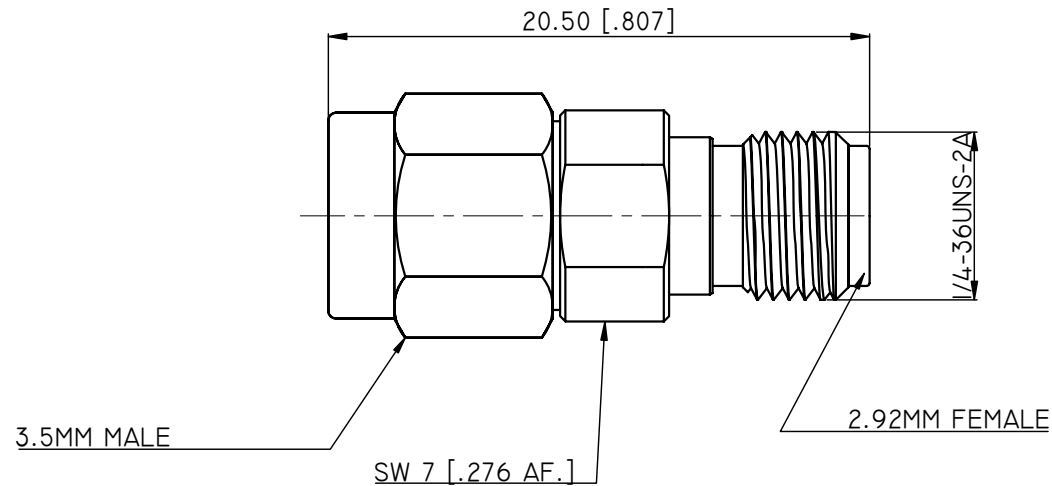

DRAWN L. YANG	DATE 05/29/15			
CHECKED X. B. YANG	DATE 05/29/15			
APPROVED J. QU	DATE 05/29/15			
<small>UNLESS OTHERWISE SPECIFIED DIMENSIONS ARE IN MILLIMETERS, DIMENSIONS IN [ ] ARE IN INCHES FOR CUSTOMER REFERENCE ONLY UNLESS OTHERWISE SPECIFIED TOLERANCE ARE:</small>		<small>THESE DRAWINGS AND SPECIFICATIONS ARE THE PROPERTY OF ANOISON ELECTRONICS LTD AND SHOULD NOT BE USED WITHOUT WRITTEN PERMISSION COPYRIGHT © 2015 ANOISON</small>		
<small>.XX ±0.13 [.005"] .X ±0.20 [.008"] X ±0.50 [.019"] .X° ±1° X° ±2°</small>		<b>TITLE</b> PRECISION ADAPTER, 2.92MM FEMALE TO 3.5MM MALE		
<small>VIEW</small> 		<b>PART NO.</b> PA2925D		
<small>SIZE</small> A3		<small>SCALE</small> 5:1	<small>SHEET</small> 1/1	<small>REV.</small> A