

MATERIAL & FINISH:

1. BODY: STAINLESS STEEL, PASSIVATED
2. CENTER CONTACT: BERYLLIUM COPPER ALLOY, GOLD PLATED
3. FASTENING NUT: STAINLESS STEEL, PASSIVATED
4. WASHER: PHOSPHOR BRONZE
5. INSULATOR: MPP0/PEI

ENVIRONMENTAL DATA:

1. TEMPERATURE RANGE: -55°C~+125°C
2. 2002/95/EC (RoHS): COMPLIANT

ELECTRICAL SPECIFICATIONS:

1. IMPEDANCE: 50 Ω
2. FREQUENCY RANGE: DC~33GHZ
3. VSWR: 1.15 MAX

REVISIONS

REV.	DESCRIPTION	DATE	APPROVED
A	INITIAL RELEASE	05/29/15	J. QU

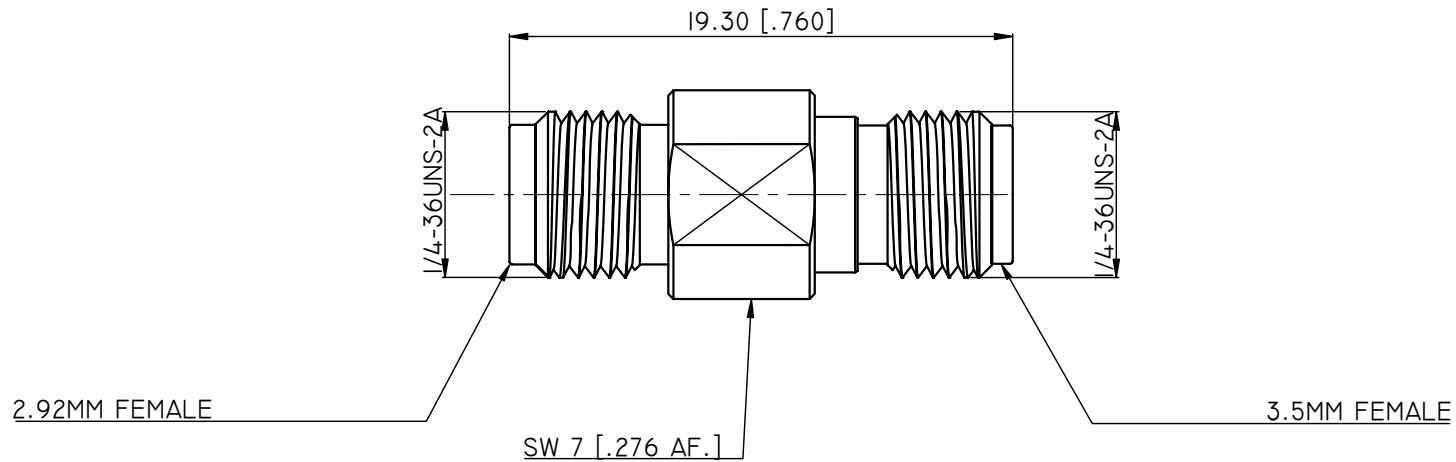

DRAWN	L. YANG	DATE	05/29/15
CHECKED	X. B. YANG	DATE	05/29/15
APPROVED	J. QU	DATE	05/29/15
UNLESS OTHERWISE SPECIFIED DIMENSIONS ARE IN MILLIMETERS, DIMENSIONS IN [] ARE IN INCHES FOR CUSTOMER REFERENCE ONLY UNLESS OTHERWISE SPECIFIED TOLERANCE ARE:		THESE DRAWINGS AND SPECIFICATIONS ARE THE PROPERTY OF ANOISON ELECTRONICS LTD AND SHOULD NOT BE USED WITHOUT WRITTEN PERMISSION COPYRIGHT © 2015 ANOISON	
.XX	±0.13 [0.005"]		
.X	±0.20 [0.008"]		
X	±0.50 [0.019"]		
.X°	±1°		
X°	±2°		



TITLE
PRECISION ADAPTER, 2.92MM FEMALE TO 3.5MM FEMALE

VIEW	PART NO. PA2925C		
	SIZE A3	SCALE 5:1	SHEET 1/1
			REV. A