

MATERIAL & FINISH:

1. BODY: STAINLESS STEEL, PASSIVATED
2. CENTER CONTACT: BERYLLIUM COPPER ALLOY, GOLD PLATED
3. COUPLING NUT: STAINLESS STEEL, PASSIVATED
4. INSULATOR: PEI

ENVIRONMENTAL DATA:

1. TEMPERATURE RANGE: -55°C~+125°C
2. 2011/65/EU (RoHS): COMPLIANT

ELECTRICAL DATA:

1. IMPEDANCE: 50 Ω
2. FREQUENCY RANGE: DC~27 GHz
3. VSWR: 1.15 MAX.

REVISIONS			
REV.	DESCRIPTION	DATE	APPROVED
A	INITIAL RELEASE	06/02/15	J. QU

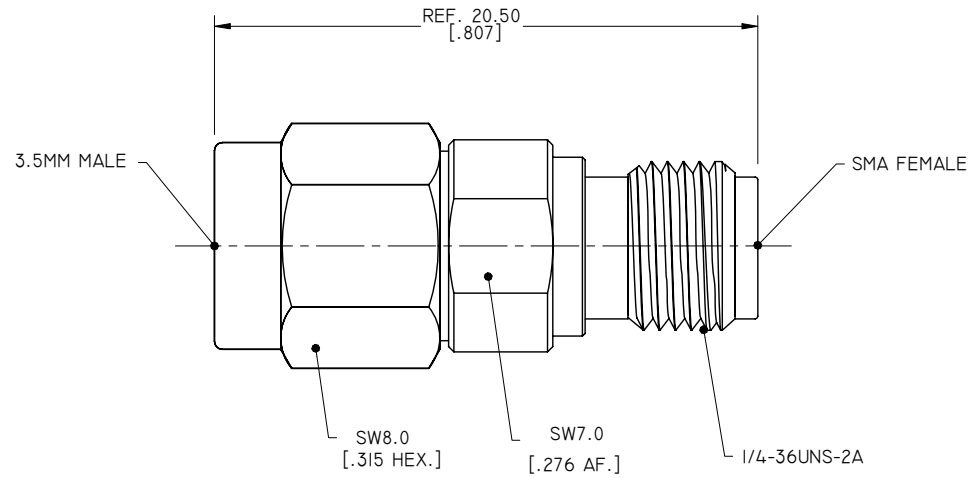

DRAWN	L. YANG	DATE	06/02/15
CHECKED	X. B. YANG	DATE	06/02/15
APPROVED	J. QU	DATE	06/02/15
UNLESS OTHERWISE SPECIFIED DIMENSIONS ARE IN MILLIMETERS, DIMENSIONS IN [] ARE IN INCHES FOR CUSTOMER REFERENCE ONLY UNLESS OTHERWISE SPECIFIED TOLERANCE ARE:		THESE DRAWINGS AND SPECIFICATIONS ARE THE PROPERTY OF ANOISON ELECTRONICS LTD AND SHOULD NOT BE USED WITHOUT WRITTEN PERMISSION COPYRIGHT © 2015 ANOISON ELECTRONICS LTD	
.XX	±0.13 [.005"]		
.X	±0.20 [.008"]		
X	±0.50 [.019"]		
.X°	±1°		
X°	±2°		



TITLE			
PRECISION ADAPTER 3.5MM MALE TO SMA FEMALE			
VIEW		PART NO.	
		PA2521B	
SIZE	SCALE	SHEET	REV.
A3	5:1	1/1	A