

4

3

2

1

**MATERIAL & FINISH:**

- 1 BODY: STAINLESS STEEL, PASSIVATED
- 2 CENTER CONTACT: BERYLLIUM COPPER ALLOY, GOLD PLATED
- 3 INSULATOR: PEI
- 4 COUPLING NUT: STAINLESS STEEL, PASSIVATED

**ELECTRICAL SPECIFICATIONS:**

- 1 IMPEDANCE: 50 Ω
- 2 FREQUENCY RANGE: DC~40GHZ
- 3 VSWR: 1.25 MAX.

**ENVIRONMENTAL DATA:**

- 1 TEMPERATURE RANGE: -55°C~+125°C
- 2 2011/65/EU (RoHS): COMPLIANT AND 2015/863/(RoHS): COMPLIANT  
1999/45/EC(REACH): COMPLIANT

REVISIONS			
REV.	DESCRIPTION	DATE	APPROVED
A	INITIAL RELEASE	04/28/19	J. QU
B	CHANGED DRAWING	04/21/21	J. QU

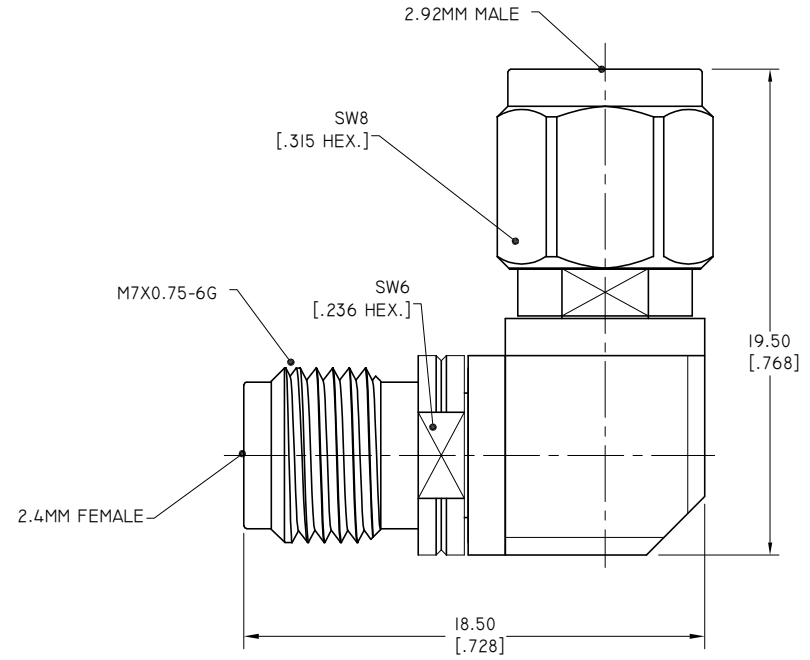

DRAWN	W. YANG	DATE	04/21/21
CHECKED	X. B. YANG	DATE	04/21/21
APPROVED	J. QU	DATE	04/21/21
UNLESS OTHERWISE SPECIFIED DIMENSIONS ARE IN MILLIMETERS, DIMENSIONS IN [ ] ARE IN INCHES FOR CUSTOMER REFERENCE ONLY UNLESS OTHERWISE SPECIFIED TOLERANCE ARE:		THESE DRAWINGS AND SPECIFICATIONS ARE THE PROPERTY OF ANOISON ELECTRONICS LTD AND SHOULD NOT BE USED WITHOUT WRITTEN PERMISSION COPYRIGHT © 2021 ANOISON ELECTRONICS LTD	
.XX	±0.13 [0.005"]		
.X	±0.20 [0.008"]		
X	±0.50 [0.019"]		
X°	±1°		
X°	±2°		

**TITLE**  
PRECISION ADAPTER, RIGHT ANGLE 2.4MM FEMALE TO 2.92MM MALE

**VIEW**

**PART NO.** PA2229M

<b>SIZE</b> A3	<b>SCALE</b> 5:1	<b>SHEET</b> 1/1	<b>REV.</b> B
-------------------	---------------------	---------------------	------------------

D  
C  
B  
A

D  
C  
B  
A

4

3

2

1