

4 3 2 1

MATERIAL & FINISH:

- 1 BODY: STAINLESS STEEL, PASSIVATED
- 2 CENTER CONTACT: BERYLLIUM COPPER ALLOY, GOLD PLATED
- 3 INSULATOR: PEI

ELECTRICAL SPECIFICATIONS:

- 1 IMPEDANCE: 50 Ω
- 2 FREQUENCY RANGE: DC-50GHZ
- 3 VSWR: 1.25 MAX.

ENVIRONMENTAL DATA:

- 1 TEMPERATURE RANGE: -55°C~+125°C
- 2 2011/65/EU (RoHS): COMPLIANT AND 2015/863/(RoHS): COMPLIANT
- 1999/45/EC(REACH): COMPLIANT

REVISIONS			
REV.	DESCRIPTION	DATE	APPROVED
A	INITIAL RELEASE	07/17/19	J. QU
B	DRAWING CHANGED	03/10/21	J. QU

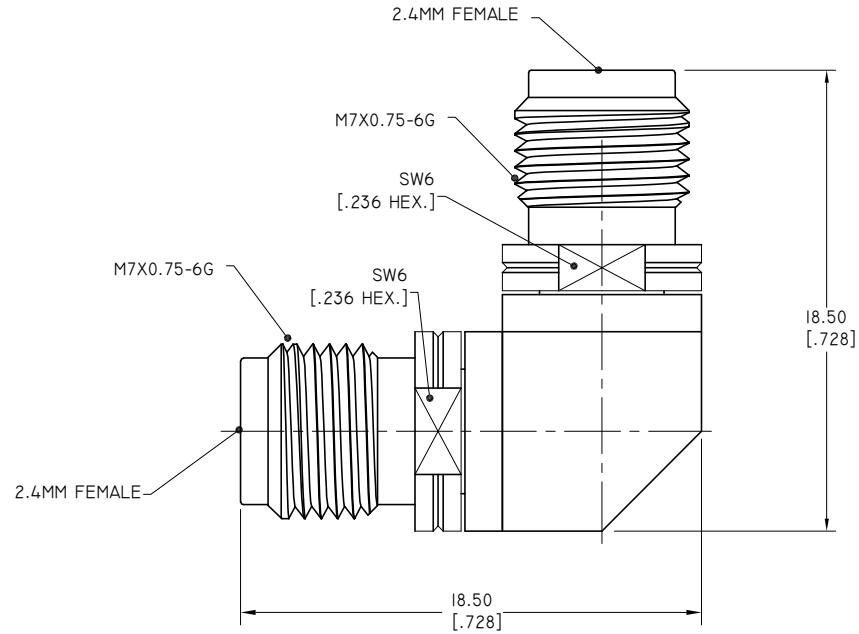

DRAWN	W. YANG	DATE	03/10/21
CHECKED	X. B. YANG	DATE	03/10/21
APPROVED	J. QU	DATE	03/10/21
UNLESS OTHERWISE SPECIFIED DIMENSIONS ARE IN MILLIMETERS, DIMENSIONS IN [] ARE IN INCHES FOR CUSTOMER REFERENCE ONLY UNLESS OTHERWISE SPECIFIED TOLERANCE ARE:		THESE DRAWINGS AND SPECIFICATIONS ARE THE PROPERTY OF ANOISON ELECTRONICS LTD AND SHOULD NOT BE USED WITHOUT WRITTEN PERMISSION COPYRIGHT © 2021 ANOISON ELECTRONICS LTD	
.XX	±0.13 [0.005"]		
.X	±0.20 [0.008"]		
X	±0.50 [0.019"]		
X°	±1°		
X°	±2°		

TITLE
PRECISION ADAPTER, RIGHT ANGLE 2.4MM FEMALE TO 2.4MM FEMALE

VIEW

PART NO. PA2222L

SIZE A3	SCALE 5:1	SHEET 1/1	REV. B
-------------------	---------------------	---------------------	------------------

4 3 2 1