

4 3 2 1

MATERIAL & FINISH:

- 1 BODY: STAINLESS STEEL, PASSIVATED
- 2 CENTER CONTACT: BERYLLIUM COPPER ALLOY, GOLD PLATED
- 3 COUPLING NUT: STAINLESS STEEL, PASSIVATED
- 4 INSULATOR: PEI

ELECTRICAL DATA:

- 1 IMPEDANCE: 50 Ω
- 2 FREQUENCY RANGE: DC~50 GHZ
- 3 VSWR: 1.20 MAX.

ENVIRONMENTAL DATA:

- 1 TEMPERATURE RANGE: -55°C~+165°C
- 2 2011/65/EU (RoHS): COMPLIANT

APPLICABLE STANDARDS:

- 1 INTERFACE ACCORDING TO: MIL-STD-348

REVISIONS			
REV.	DESCRIPTION	DATE	APPROVED
A	INITIAL RELEASE	06/07/16	J. QU
B	CHANGED ELECTRICAL DATA	04/23/18	J. QU

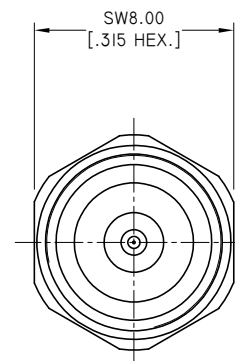
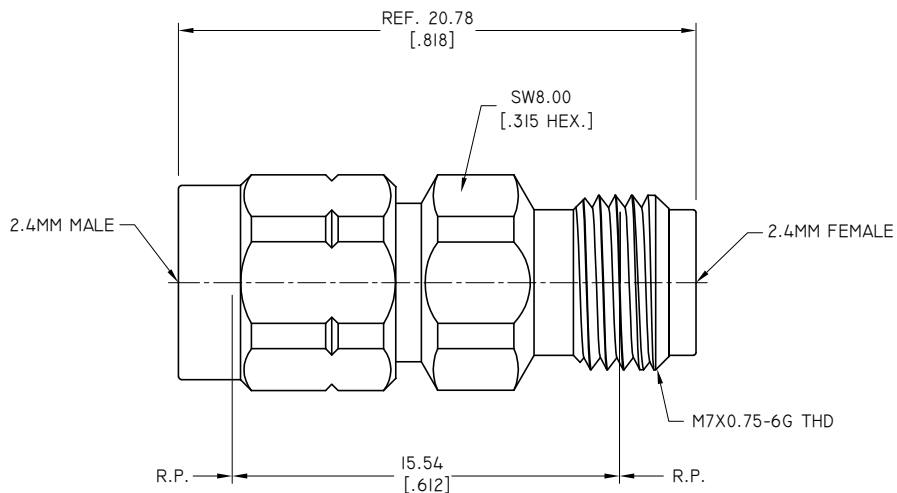

DRAWN	P. CHEN	DATE	04/23/18
CHECKED	L. YANG	DATE	04/23/18
APPROVED	J. QU	DATE	04/23/18
UNLESS OTHERWISE SPECIFIED DIMENSIONS ARE IN MILLIMETERS, DIMENSIONS IN [] ARE IN INCHES FOR CUSTOMER REFERENCE ONLY UNLESS OTHERWISE SPECIFIED TOLERANCE ARE:		THESE DRAWINGS AND SPECIFICATIONS ARE THE PROPERTY OF ANOISON ELECTRONICS LTD AND SHOULD NOT BE USED WITHOUT WRITTEN PERMISSION COPYRIGHT © 2018 ANOISON ELECTRONICS LTD	
.XX	±0.13 [.005"]		
.X	±0.20 [.008"]		
X	±0.50 [.019"]		
X°	±1°		
X°	±2°		

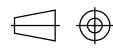

TITLE
PRECISION ADAPTER
2.4MM MALE TO 2.4MM FEMALE

VIEW 

PART NO. PA2222B

SIZE A3	SCALE 5:1	SHEET 1/1	REV. B
-------------------	---------------------	---------------------	------------------

4 3 2 1