

MATERIAL & FINISH:

1. BODY: STAINLESS STEEL, PASSIVATED
2. CENTER CONTACT: BERYLLIUM COPPER ALLOY, GOLD PLATED
3. INSULATOR: PTFE & PEI
4. COUPLING NUT: STAINLESS STEEL, PASSIVATED

ENVIRONMENTAL DATA:



1. TEMPERATURE RANGE: -55°C~+125°C
2. 2011/65/EU (RoHS): COMPLIANT

ELECTRICAL SPECIFICATIONS:

1. IMPEDANCE: 50 Ω
2. FREQUENCY RANGE: DC~8GHZ
3. VSWR: 1.15 MAX

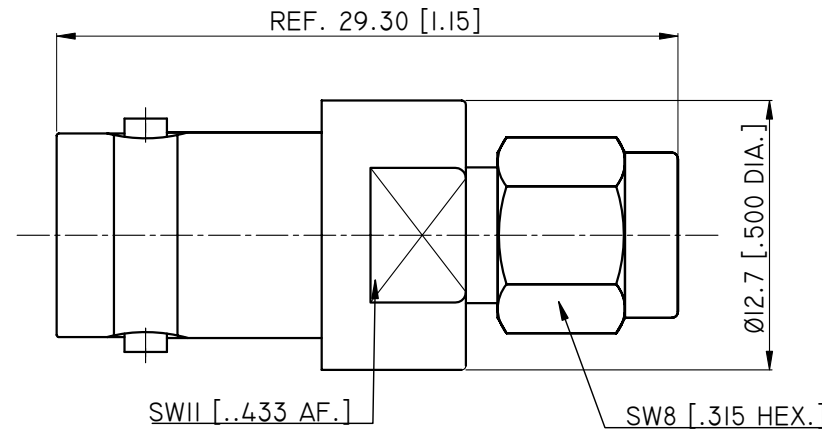
REVISIONS			
REV.	DESCRIPTION	DATE	APPROVED
A	INITIAL RELEASE	07/03/14	J. QU



DRAWN	L. YANG	DATE	07/03/14		
CHECKED	X. B. YANG	DATE	07/03/14		
APPROVED	J. QU	DATE	07/03/14		
UNLESS OTHERWISE SPECIFIED DIMENSIONS ARE IN MILLIMETERS, DIMENSIONS IN [] ARE IN INCHES FOR CUSTOMER REFERENCE ONLY UNLESS OTHERWISE SPECIFIED TOLERANCE ARE:		THESE DRAWINGS AND SPECIFICATIONS ARE THE PROPERTY OF ANOISON ELECTRONICS LTD AND SHOULD NOT BE USED WITHOUT WRITTEN PERMISSION COPYRIGHT © 2013 ANOISON			
.XX ±0.13 [.005"]		<div style="text-align: center;">  </div>			
.X ±0.20 [.008"]					
X ±0.50 [.019"]					
.X° ±1°					
X° ±2°					
TITLE PRECISION ADAPTER , BNC FEMALE TO SMA MALE					
VIEW		PART NO. PA2131D			
		SIZE A3	SCALE 4:1	SHEET 1/1	REV. A