

MATERIAL & FINISH:  
STAINLESS STEEL, PASSIVATED

ENVIRONMENTAL DATA:  
1 2011/65/EU (RoHS) AND 2015/863/(RoHS): COMPLIANT  
2 1907/2006/EC (REACH): COMPLIANT

REVISIONS			
REV.	DESCRIPTION	DATE	APPROVED
A	INITIAL RELEASE	08/07/19	J QU
B	MARKING ADDED	02/22/21	J QU

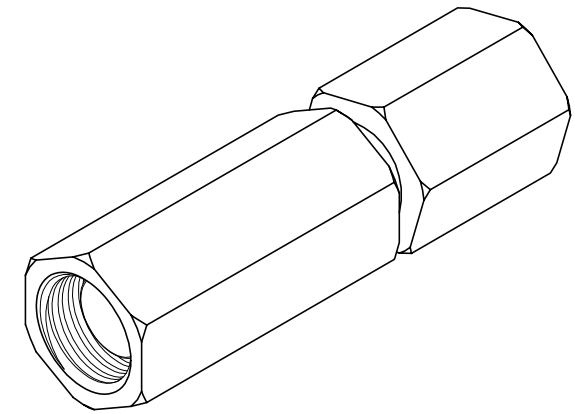
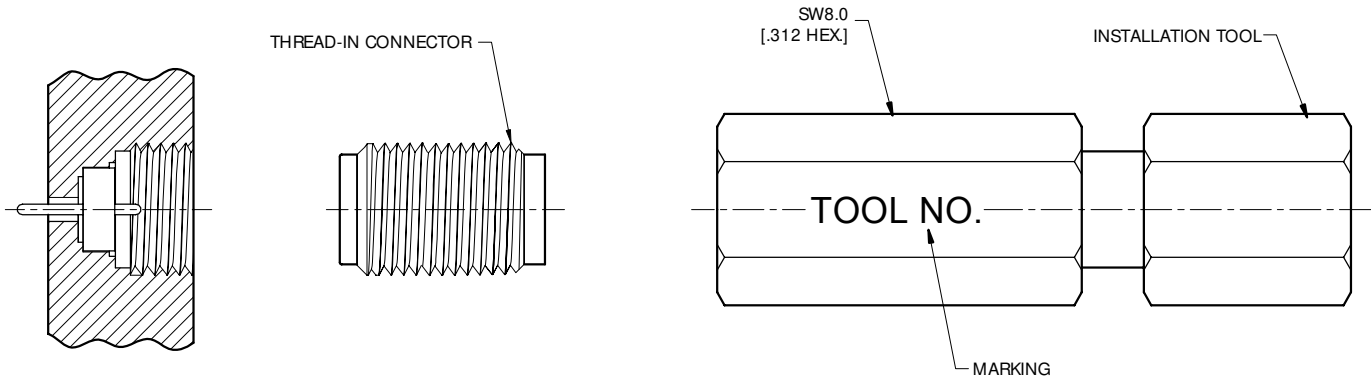

TOOL NO.	THREAD-IN CONNECTOR SERIES	RECOMMENDED INSTALL TORQUE	CONNECTOR COUPLING NUT TORQUE
IT22001	2.40 MM AND 1.85 MM	18 IN.LBS	9 IN.LBS
IT29001	2.92 MM 3.5 MM AND SMA	18 IN.LBS	9 IN.LBS
IT91001	SSMA	16 IN.LBS	8 IN.LBS

DRAWN	X. B. YANG	DATE	02/22/21
CHECKED	W. YANG	DATE	02/22/21
APPROVED	J QU	DATE	02/22/21
UNLESS OTHERWISE SPECIFIED DIMENSIONS ARE IN MILLIMETERS. DIMENSIONS IN [ ] ARE IN INCHES FOR CUSTOMER REFERENCE ONLY UNLESS OTHERWISE SPECIFIED TOLERANCE ARE:		THESE DRAWINGS AND SPECIFICATIONS ARE THE PROPERTY OF ANOISON ELECTRONICS LTD AND SHOULD NOT BE USED WITHOUT WRITTEN PERMISSION COPYRIGHT © 2021 ANOISON ELECTRONICS LTD	
.XX	±0.13 [.005"]		
.X	±0.20 [.008"]		
X	±0.50 [.019"]		
.X°	±1°		
X°	±2°		

**ANOISON**

TITLE  
THREAD-IN CONNECTOR SERIES INSTALLATION TOOLS

VIEW

PART NO.  
ITXXXXX

SIZE A3	SCALE 5:1	SHEET 1/1	BREV. A
------------	--------------	--------------	------------