

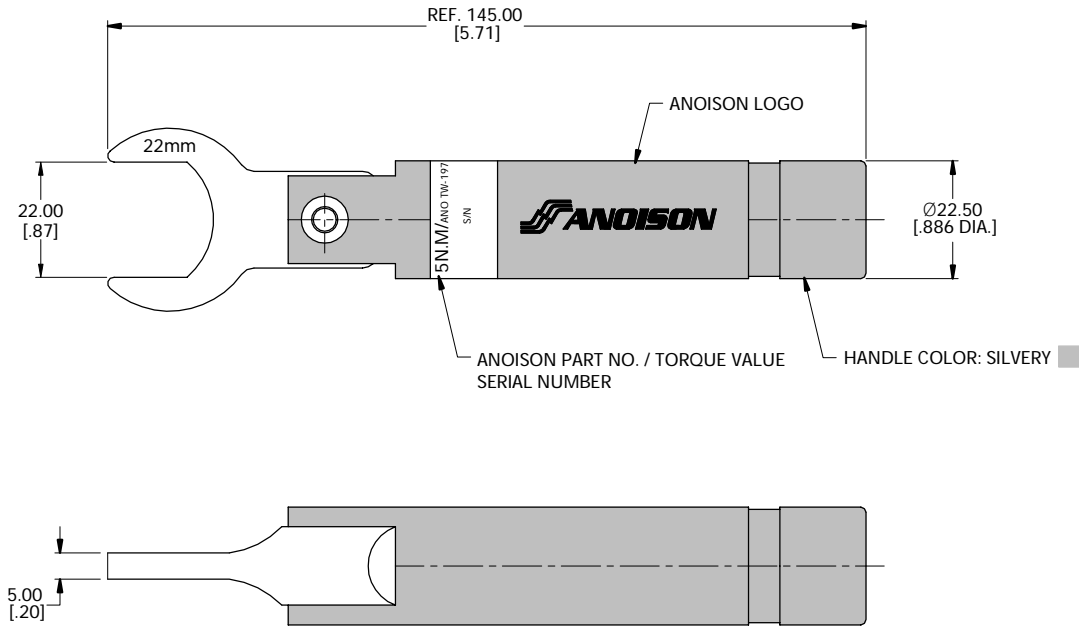

MATERIAL & FINISH:

- 1 HEAD: STAINLESS STEEL, PASSIVATED
- 2 HANDLE: ALUMINUM, OXIDATION
- 3 SPRING: MANGANESE ALLOY
- 4 STEEL BALL: STAINLESS STEEL, PASSIVATED
- 5 SPRING PIN: STAINLESS STEEL, PASSIVATED
- 6 OTHER METAL: STAINLESS STEEL, PASSIVATED

REVISIONS			
REV.	DESCRIPTION	DATE	APPROVED
A	INITIAL RELEASE	03/24/26	J. Q

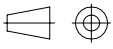

- 1. TORQUE VALUE: 5±0.2 NM [44.25±1.77 IN.LBS]
- 2. SIZE: 22 MM [.866 IN.]
- 3. PRINT CONTENT ON HANDLE: ANOISON LOGO
- 4. PACKAGE: PER WOODEN BOX ONE TORQUE WRENCH

DRAWN	X. Y	DATE	03/24/26				
CHECKED	W. Y	DATE	03/24/26				
APPROVED	J. Q	DATE	03/24/26				
UNLESS OTHERWISE SPECIFIED DIMENSIONS ARE IN MILLIMETERS, DIMENSIONS IN [] ARE IN INCHES FOR CUSTOMER REFERENCE ONLY UNLESS OTHERWISE SPECIFIED TOLERANCE ARE:		THESE DRAWINGS AND SPECIFICATIONS ARE THE PROPERTY OF ANOISON GROUP. THEY SHALL NOT BE REPRODUCED OR USED WITHOUT WRITTEN PERMISSION. © 2026 ANOISON GROUP. ALL RIGHTS RESERVED.		TITLE TORQUE WRENCH FOR 4.3-10 TYPE CONNECTORS PRESET TORQUE= 5±0.2 NM [44.25±1.77 IN.LBS] HEX SIZE 22 MM [.866 IN.]			
.XX ±0.13 [.005"] X ±0.20 [.008"] X ±0.50 [.019"] X° ±1° X° ±2°		VIEW		PART NO.		REV.	
				ANO TW-197		A	
		SIZE A3		SCALE 1:1		SHEET 1/1	