

MATERIAL & FINISH:

- 1 HEAD: STAINLESS STEEL, PASSIVATED
- 2 HANDLE: ALUMINUM, OXIDATION
- 3 SPRING: MANGANESE ALLOY
- 4 STEEL BALL: STAINLESS STEEL, PASSIVATED
- 5 SPRING PIN: STAINLESS STEEL, PASSIVATED
- 6 OTHER METAL: STAINLESS STEEL, PASSIVATED

REVISIONS			
REV.	DESCRIPTION	DATE	APPROVED
A	INITIAL RELEASE	06/26/19	J. QU

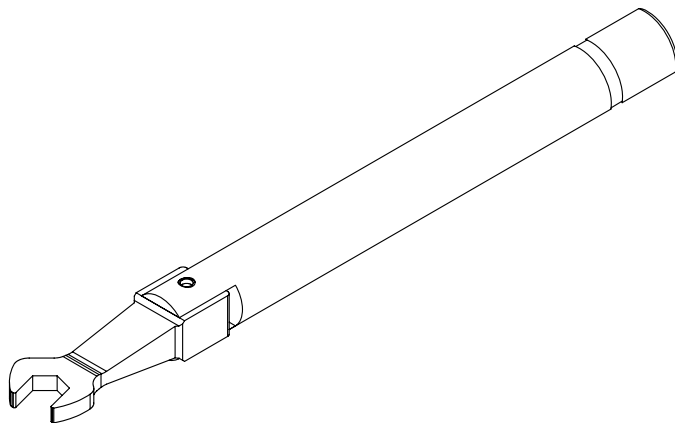
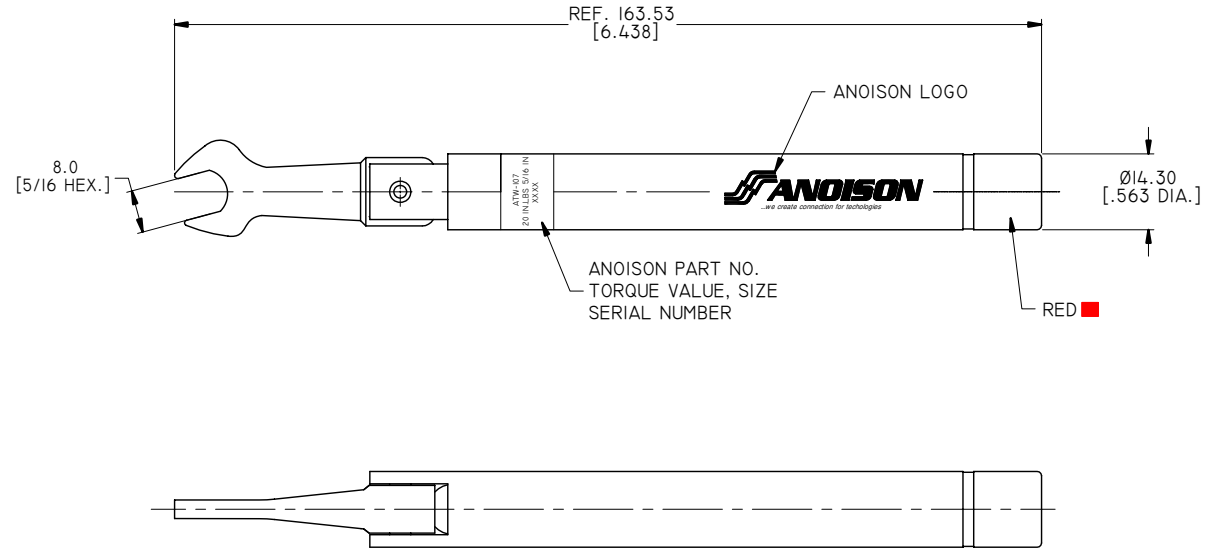

1. TORQUE VALUE: 2.26±0.09 NM [20±0.8 IN. LBS]
2. SIZE: 8.0 MM [5/16 IN.]
3. PRINT CONTENT ON HANDLE(WHITE COLOR): ANOISON LOGO

DRAWN	X. B. YANG	DATE	06/26/19		
CHECKED	W. YANG	DATE	06/26/19		
APPROVED	J. QU	DATE	06/26/19		
UNLESS OTHERWISE SPECIFIED DIMENSIONS ARE IN MILLIMETERS, DIMENSIONS IN [ ] ARE IN INCHES FOR CUSTOMER REFERENCE ONLY UNLESS OTHERWISE SPECIFIED TOLERANCE ARE:		THESE DRAWINGS AND SPECIFICATIONS ARE THE PROPERTY OF ANOISON ELECTRONICS LTD AND SHOULD NOT BE USED WITHOUT WRITTEN PERMISSION COPYRIGHT © 2019 ANOISON ELECTRONICS LTD		TITLE	TORQUE WRENCH FOR 8MM PRESET TORQUE= 2.26±0.09 NM [20±0.8 IN.LBS] HEX SIZE 8.0 MM [5/16 IN.]
.XX ±0.13 [.005"] .X ±0.20 [.008"] X ±0.50 [.019"] .X° ±1° X° ±2°		VIEW		PART NO.	ANO TW-107
				SIZE	A3
				SCALE	1:1
				SHEET	1/1
				REV.	A