

REVISIONS			
REV.	DESCRIPTION	DATE	APPROVED
A	INITIAL RELEASE	01/11/18	J. QU

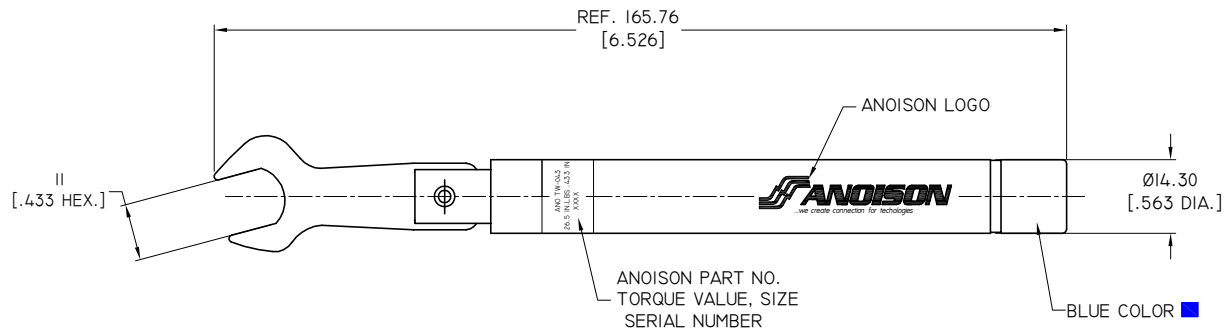

1. TORQUE VALUE: 3.00±0.12 NM [26.5±1.06 IN. LBS]
2. SIZE: 11 MM [.433 IN.]
3. PRINT CONTENT ON HANDLE(WHITE COLOR): ANOISON LOGO

DRAWN	W. YANG	DATE	01/11/18									
CHECKED	X. B. YANG	DATE	01/11/18									
APPROVED	J. QU	DATE	01/11/18									
UNLESS OTHERWISE SPECIFIED DIMENSIONS ARE IN MILLINMETERS, DIMENSIONS IN [ ] ARE IN INCHES FOR CUSTOMER REFERENCE ONLY UNLESS OTHERWISE SPECIFIED TOLERANCE ARE:		THESE DRAWINGS AND SPECIFICATIONS ARE THE PROPERTY OF ANOISON ELECTRONICS LTD AND SHOULD NOT BE USED WITHOUT WRITTEN PERMISSION COPYRIGHT © 2018 ANOISON ELECTRONICS LTD		<b>TITLE</b> TORQUE WRENCH FOR NEX10 TYPE CONNECTORS PRESET TORQUE= 3.00±0.12 NM [26.5±1.06 IN. LBS] HEX SIZE 11 MM [.433 IN.]								
.XX ±0.13 [.005"] .X ±0.20 [.008"] X ±0.50 [.019"] .X° ±1° X° ±2°		VIEW		<b>PART NO.</b> ANO TW-043								
				<table border="1"> <tr> <th>SIZE</th> <th>SCALE</th> <th>SHEET</th> <th>REV.</th> </tr> <tr> <td>A3</td> <td>1:1</td> <td>1/1</td> <td>A</td> </tr> </table>	SIZE	SCALE	SHEET	REV.	A3	1:1	1/1	A
SIZE	SCALE	SHEET	REV.									
A3	1:1	1/1	A									