

4

3

2

1

D

D

C

C

B

B

A

A

4

3

2

1

REVISIONS			
REV.	DESCRIPTION	DATE	APPROVED
A	INITIAL RELEASE	06/01/17	J. QU

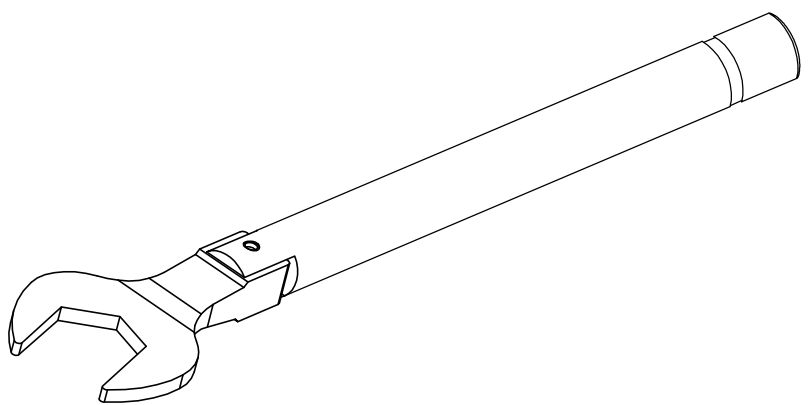
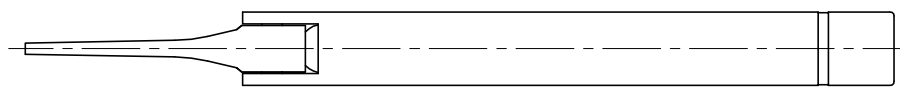
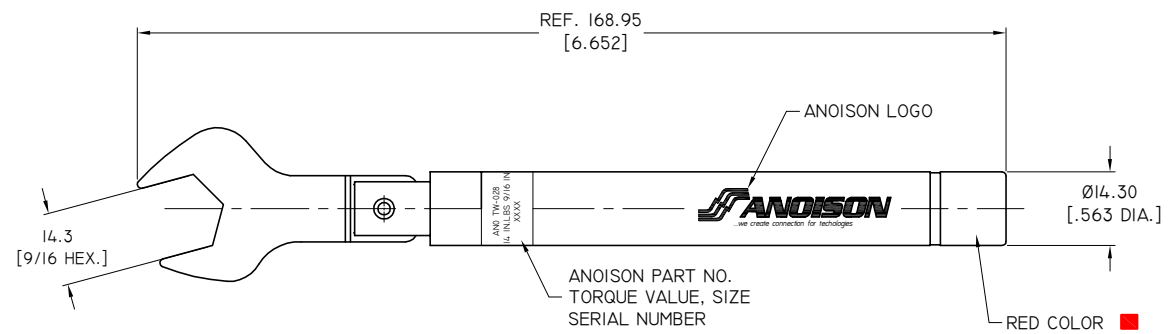

1. TORQUE VALUE: 1.58±0.06 NM [14±0.56 IN.LBS]
2. SIZE: 14.3 MM [9/16 IN]
3. PRINT CONTENT ON HANDLE(WHITE COLOR): ANOISON LOGO

DRAWN	X. B. YANG	DATE	06/01/17
CHECKED	L. YANG	DATE	06/01/17
APPROVED	J. QU	DATE	06/01/17
UNLESS OTHERWISE SPECIFIED DIMENSIONS ARE IN MILLIMETERS, DIMENSIONS IN [] ARE IN INCHES FOR CUSTOMER REFERENCE ONLY UNLESS OTHERWISE SPECIFIED TOLERANCE ARE:		THESE DRAWINGS AND SPECIFICATIONS ARE THE PROPERTY OF ANOISON ELECTRONICS LTD AND SHOULD NOT BE USED WITHOUT WRITTEN PERMISSION COPYRIGHT © 2017 ANOISON ELECTRONICS LTD	
.XX	±0.13 [.005"]		
.X	±0.20 [.008"]		
X	±0.50 [.019"]		
.X°	±1°		
X°	±2°		



TITLE
TORQUE WRENCH FOR TNC TYPE CONNECTORS
PRESET TORQUE= 1.58±0.06 NM [14±0.56 IN.LBS]
HEX SIZE 14.3 MM [9/16 IN.]

VIEW	PART NO. ANO TW-028		
	SIZE A3	SCALE 1:1	SHEET 1/1
		REV. A	