

4

3

2

1

REVISIONS			
REV.	DESCRIPTION	DATE	APPROVED
A	INITIAL RELEASE	12/09/14	J. QU
B	0.68±0.03 NM [6±0.24 IN.LBS] WAS 0.68±0.03 NM [6±0.3 IN.LBS]	02/08/17	J. QU

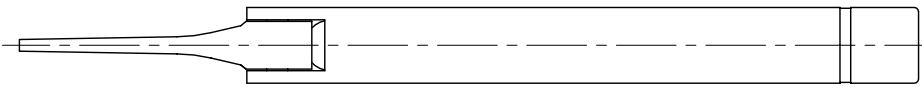
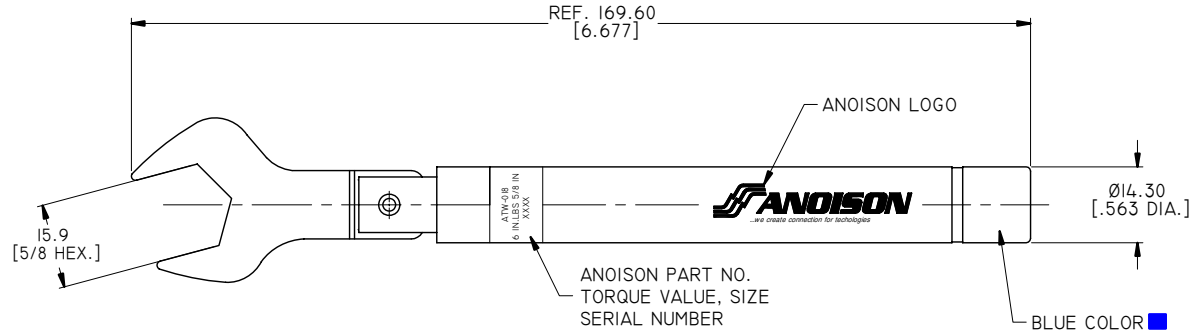

- TORQUE VALUE; 0.68±0.03 NM [6±0.24 IN.LBS]
- SIZE: 15.9 MM [5/8 IN.]
- PRINT CONTENT ON HANDLE(WHITE COLOR): ANOISON LOGO

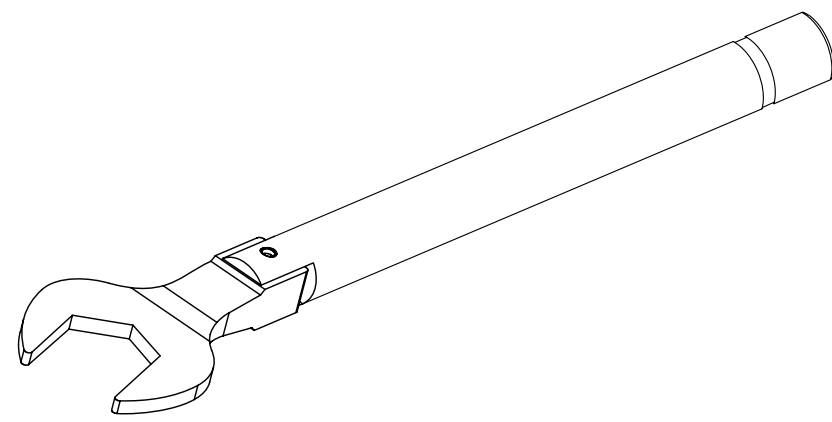

DRAWN	X. B. YANG	DATE	02/08/17
CHECKED	L. YANG	DATE	02/08/17
APPROVED	J. QU	DATE	02/08/17
UNLESS OTHERWISE SPECIFIED DIMENSIONS ARE IN MILLIMETERS, DIMENSIONS IN [] ARE IN INCHES FOR CUSTOMER REFERENCE ONLY UNLESS OTHERWISE SPECIFIED TOLERANCE ARE:		THESE DRAWINGS AND SPECIFICATIONS ARE THE PROPERTY OF ANOISON ELECTRONICS LTD AND SHOULD NOT BE USED WITHOUT WRITTEN PERMISSION COPYRIGHT © 2017 ANOISON ELECTRONICS LTD	
.XX	±0.13 [.005"]		
.X	±0.20 [.008"]		
X	±0.50 [.019"]		
.X°	±1°		
X°	±2°		



TITLE
TORQUE WRENCH FOR TNC TYPE CONNECTORS
PRESET TORQUE= 0.68±0.03 NM [6±0.24 IN.LBS]
HEX SIZE 15.9 MM [5/8 IN.]

VIEW	PART NO. ANO TW-018		
SIZE A3	SCALE 1:1	SHEET 1/1	REV. B

4

3

2

1