

4

3

2

1

REVISIONS			
REV.	DESCRIPTION	DATE	APPROVED
A	INITIAL RELEASE	03/12/11	J. QU
B	0.9±0.04 NM [8±0.32 IN.LBS] WAS 0.92±0.05 NM [8±0.4 IN.LBS]	02/06/17	J. QU

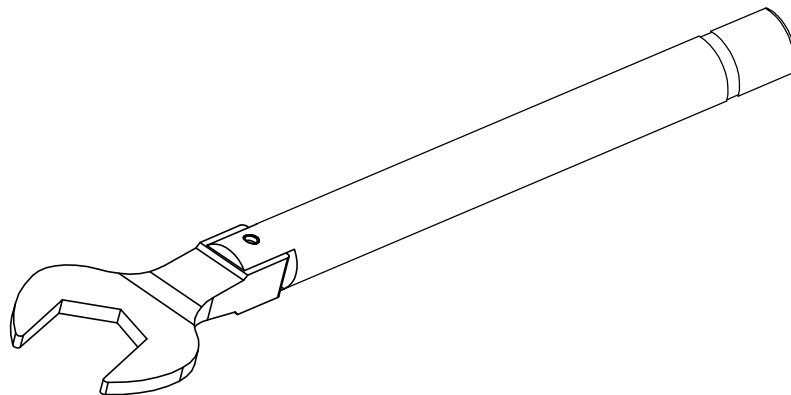
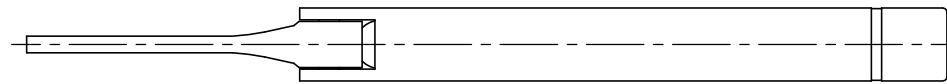
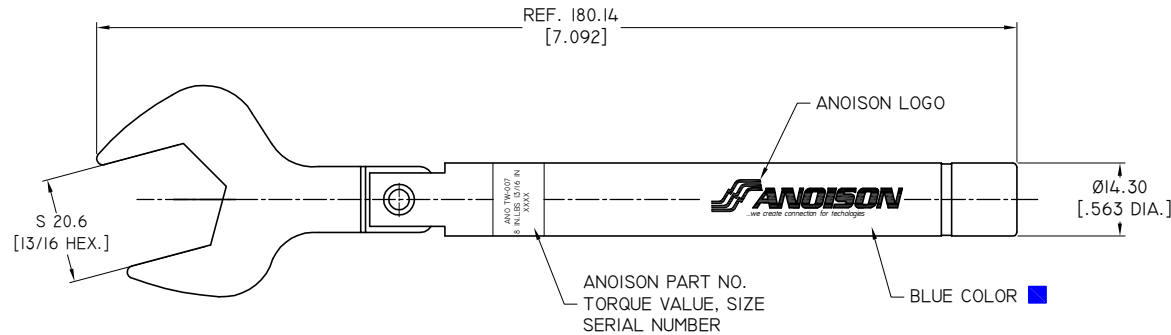

1. TORQUE VALUE: 0.9±0.04 NM [8±0.32 IN. LBS]
2. SIZE: 20.6 MM [13/16 IN.]
3. PRINT CONTENT ON HANDLE(WHITE COLOR): ANOISON LOGO

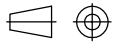
DRAWN X. B. YANG	DATE 02/06/17	 <p>...we create connection for technologies</p>	
CHECKED L. YANG	DATE 02/06/17		
APPROVED J. QU	DATE 02/06/17		
UNLESS OTHERWISE SPECIFIED DIMENSIONS ARE IN MILLINMETERS, DIMENSIONS IN [] ARE IN INCHES FOR CUSTOMER REFERENCE ONLY UNLESS OTHERWISE SPECIFIED TOLERANCE ARE: .XX ±0.13 [.005"] .X ±0.20 [.008"] X ±0.50 [.019"] .X° ±1° X° ±2°		THESE DRAWINGS AND SPECIFICATIONS ARE THE PROPERTY OF ANOISON ELECTRONICS LTD AND SHOULD NOT BE USED WITHOUT WRITTEN PERMISSION COPYRIGHT © 2017 ANOISON ELECTRONICS LTD	
TITLE TORQUE WRENCH FOR N TYPE CONNECTORS PRESET TORQUE= 0.9±0.04 NM [8±0.32 IN.LBS] HEX SIZE 20.6 MM [13/16 IN.]		VIEW 	
PART NO. ANO TW-007			
SIZE A3	SCALE 1:1	SHEET 1/1	REV. B

4

3

2

1

D

D

C

C

B

B

A

A