

4

3

2

1

REVISIONS			
REV.	DESCRIPTION	DATE	APPROVED
A	INITIAL RELEASE	02/27/11	J. QU
B	0.9±0.04 NM [8±0.32 IN.LBS] WAS 0.92±0.05 NM [8±0.4 IN.LBS]	02/06/17	J. QU

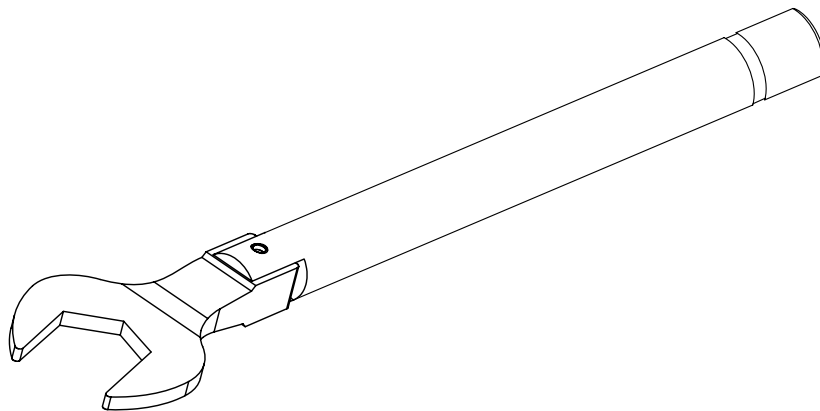
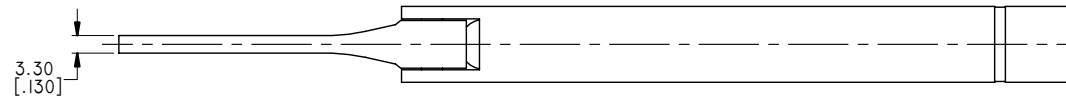
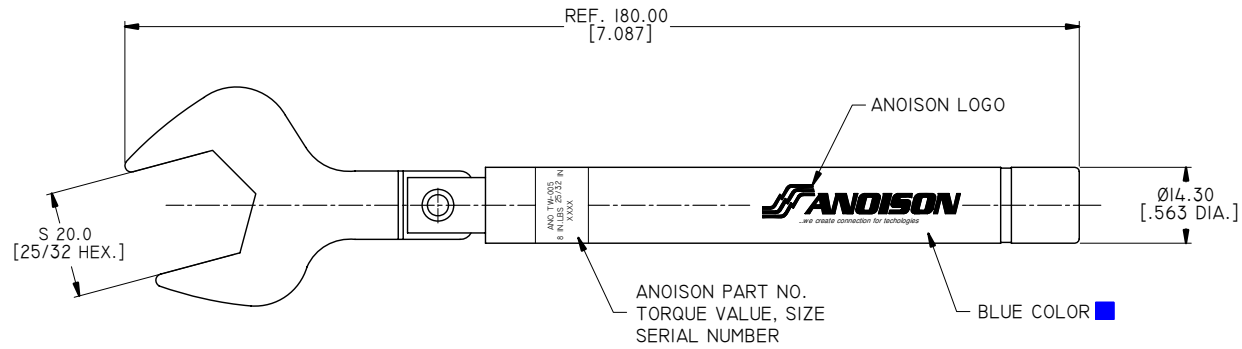

1. TORQUE VALUE: 0.9±0.04 NM [8±0.32 IN. LBS]
2. SIZE: 20 MM [25/32 IN.]
3. PRINT CONTENT ON HANDLE(WHITE COLOR): ANOISON LOGO

DRAWN	X. B. YANG	DATE	02/06/17
CHECKED	L. YANG	DATE	02/06/17
APPROVED	J. QU	DATE	02/06/17
UNLESS OTHERWISE SPECIFIED DIMENSIONS ARE IN MILLIMETERS, DIMENSIONS IN [] ARE IN INCHES FOR CUSTOMER REFERENCE ONLY UNLESS OTHERWISE SPECIFIED TOLERANCE ARE:		THESE DRAWINGS AND SPECIFICATIONS ARE THE PROPERTY OF ANOISON ELECTRONICS LTD AND SHOULD NOT BE USED WITHOUT WRITTEN PERMISSION COPYRIGHT © 2017 ANOISON ELECTRONICS LTD	
.XX	±0.13 [.005"]		
.X	±0.20 [.008"]		
X	±0.50 [.019"]		
.X°	±1°		
X°	±2°		



TITLE			
TORQUE WRENCH FOR N TYPE CONNECTORS PRESET TORQUE= 0.9±0.04 NM [8±0.32 IN.LBS] HEX SIZE 20 MM [25/32 IN.]			
VIEW		PART NO.	
		ANO TW-005	
SIZE	SCALE	SHEET	REV.
A3	1:1	1/1	B

4

3

2

1