

4

3

2

1

REVISIONS			
REV.	DESCRIPTION	DATE	APPROVED
A	INITIAL RELEASE	02/18/11	J. QU
B	1.6±0.06 NM [14±0.56 IN.LBS] WAS 1.6±0.09 NM [14±0.8 IN.LBS]	02/06/17	J. QU

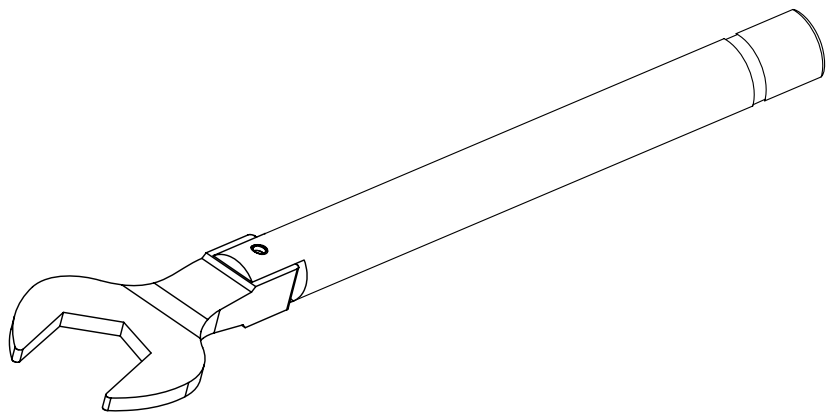
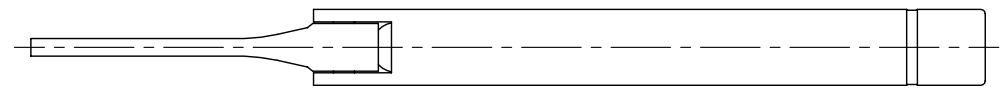
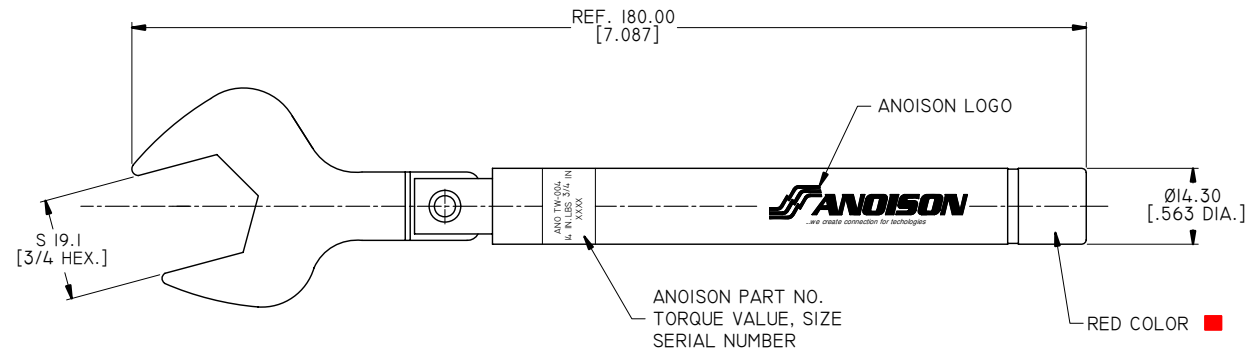

1. TORQUE VALUE: 1.6±0.06 NM [14±0.56 IN.LBS]
2. SIZE: 19.1 MM [3/4 IN.]
3. PRINT CONTENT ON HANDLE(WHITE COLOR): ANOISON LOGO

DRAWN	X. B. YANG	DATE	02/06/17
CHECKED	L. YANG	DATE	02/06/17
APPROVED	J. QU	DATE	02/06/17
UNLESS OTHERWISE SPECIFIED DIMENSIONS ARE IN MILLIMETERS, DIMENSIONS IN [ ] ARE IN INCHES FOR CUSTOMER REFERENCE ONLY UNLESS OTHERWISE SPECIFIED TOLERANCE ARE:		THESE DRAWINGS AND SPECIFICATIONS ARE THE PROPERTY OF ANOISON ELECTRONICS LTD AND SHOULD NOT BE USED WITHOUT WRITTEN PERMISSION COPYRIGHT © 2017 ANOISON ELECTRONICS LTD	
.XX	±0.13 [.005"]		
.X	±0.20 [.008"]		
X	±0.50 [.019"]		
.X°	±1°		
X°	±2°		



TITLE TORQUE WRENCH FOR N/7 MM TYPE CONNECTORS PRESET TORQUE= 1.6±0.06 NM [14±0.56 IN.LBS] HEX SIZE 19.1 MM [3/4 IN.]			
VIEW 		PART NO. ANO TW-004	
SIZE A3	SCALE 1:1	SHEET 1/1	REV. B

4

3

2

1