

4

3

2

1

MATERIAL & FINISH:

- 1 BODY: BRASS, GOLD PLATED
- 2 CENTER CONTACT: BERYLLIUM COPPER ALLOY, GOLD PLATED
- 3 FASTENING NUT: BRASS, NICKEL PLATED
- 4 WASHER: PHOSPHOR BRONZE, NICKEL PLATED
- 5 CRIMP FERRULE: COPPER, NICKEL PLATED
- 6 INSULATOR: PTFE

ELECTRICAL DATA:

- 1 IMPEDANCE: 75 Ω
- 2 FREQUENCY RANGE: DC~1000MHZ

ENVIRONMENTAL DATA:

- 1 TEMPERATURE RANGE: -55°C~+125°C
- 2 2011/65/EU(RoHS) AND 2015/863/(RoHS): COMPLIANT
- 3 1999/45/EC(REACH): COMPLIANT

REVISIONS			
REV.	DESCRIPTION	DATE	APPROVED
A	INITIAL RELEASE	12/06/13	J. QU
B	1. 2015/863/(RoHS): COMPLIANT ADDED 2. 1999/45/EC(REACH): COMPLIANT ADDED	09/29/18	J. QU

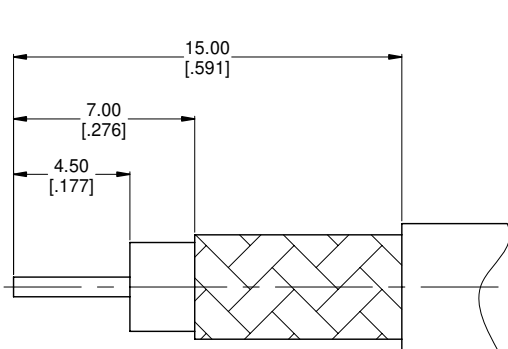
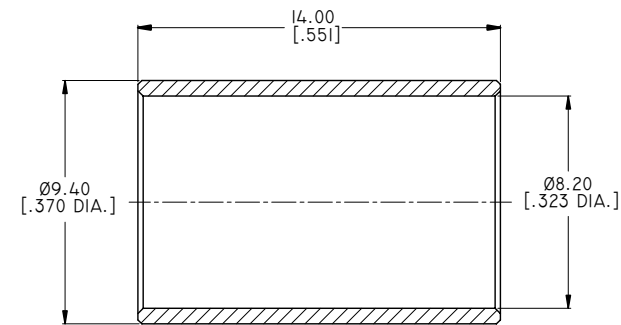
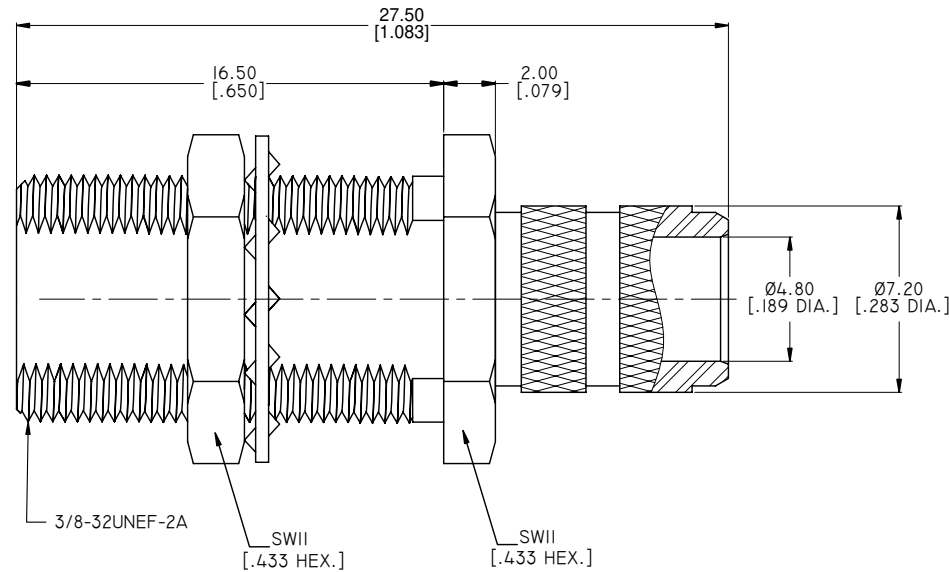

CABLE STRIPPING DIMENSIONS

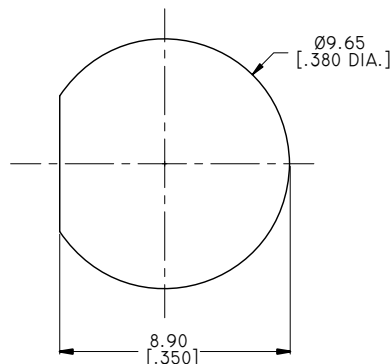

RECOMMENDED MOUNTING HOLE

DRAWN	P. CHEN	DATE	09/29/18
CHECKED	X. B. YANG	DATE	09/29/18
APPROVED	J. QU	DATE	09/29/18
UNLESS OTHERWISE SPECIFIED DIMENSIONS ARE IN MILLIMETERS, DIMENSIONS IN [ ] ARE IN INCHES FOR CUSTOMER REFERENCE ONLY UNLESS OTHERWISE SPECIFIED TOLERANCE ARE:		THESE DRAWINGS AND SPECIFICATIONS ARE THE PROPERTY OF ANOISON ELECTRONICS LTD AND SHOULD NOT BE USED WITHOUT WRITTEN PERMISSION COPYRIGHT © 2018 ANOISON ELECTRONICS LTD	
.XX	±0.13 [.005"]		
.X	±0.20 [.008"]		
X	±0.50 [.019"]		
.X°	±1°		
X°	±2°		



TITLE  
75 OHM F FEMALE BULKHEAD MOUNT  
CONNECTOR CRIMP/SOLDER ATTACHMENT FOR  
RG6-CATV, .380 INCH DD HOLE

VIEW	PART NO. ANO 9712-1001		
	SIZE A3	SCALE 5:1	SHEET 1/1
			REV. B

4

3

2

1