

MATERIAL & FINISH:

1. BODY: KOVAR, GOLD PLATED
2. CENTER CONTACT: KOVAR, GOLD PLATED
3. INSULATOR: CORNING 7070 OR EQUIVALENT

ENVIRONMENTAL DATA:

1. TEMPERATURE RANGE: -65°C~+165°C
2. 2011/65/EC (RoHS): COMPLIANT
3. HERMETIC SEAL: 10⁻⁸ STD.CM³/S

ELECTRICAL DATA:

- 1 IMPEDANCE: 50 Ω
- 2 FREQUENCY RANGE: DC~40 GHZ
- 3 VSWR (TYP): ≤ 1.25 AT DC~18 GHZ
≤ 1.35 AT 18~26.5 GHZ
- 4 INSERTION LOSS: 0.04√F(GHZ) DB
- 5 DIELECTRIC WITHSTANDING VOLTAGE: 500V

MECHANICAL DATA:

1. CENTER CONTACT RETENTION:
AXIAL FORCE--MATING ENGD: 6.7 N MIN.
AXIAL FORCE--OPPOSITE ENGD: 6.7 N MIN.

REVISIONS			
REV.	DESCRIPTION	DATE	APPROVED
A	INITIAL RELEASE	12/16/11	J. QU
B	DRAWING FORMAT CHANGED	08/08/17	J. QU

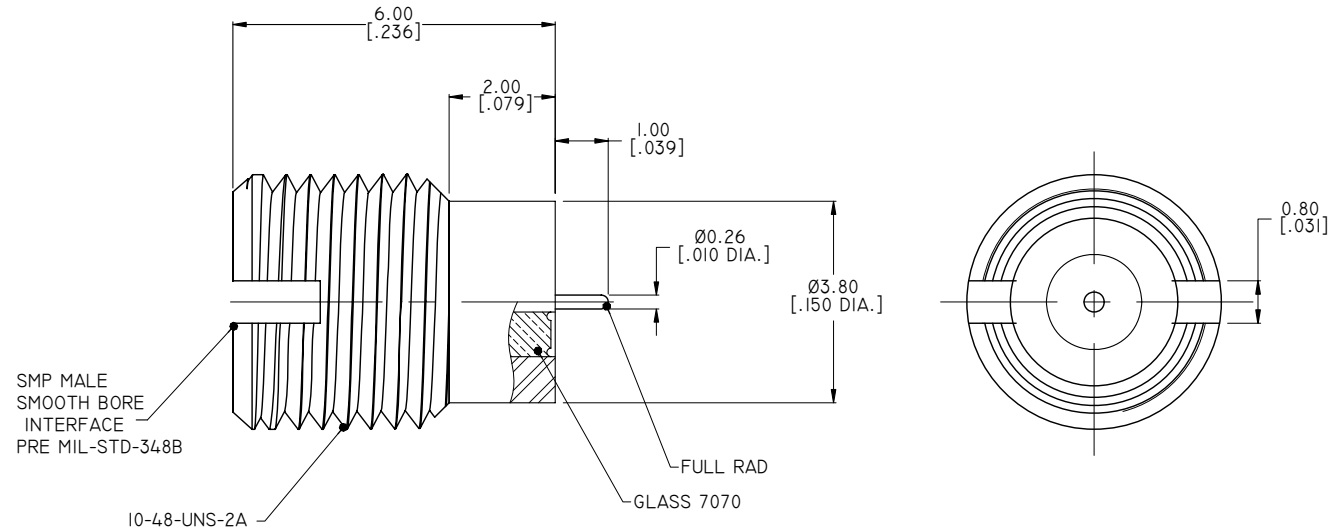

DRAWN	P. CHEN	DATE	08/08/17
CHECKED	X. B. YANG	DATE	08/08/17
APPROVED	J. QU	DATE	08/08/17
UNLESS OTHERWISE SPECIFIED DIMENSIONS ARE IN MILLIMETERS, DIMENSIONS IN [] ARE IN INCHES FOR CUSTOMER REFERENCE ONLY UNLESS OTHERWISE SPECIFIED TOLERANCE ARE:		THESE DRAWINGS AND SPECIFICATIONS ARE THE PROPERTY OF ANOISON ELECTRONICS LTD AND SHOULD NOT BE USED WITHOUT WRITTEN PERMISSION COPYRIGHT © 2017 ANOISON ELECTRONICS LTD	
.XX	±0.13 [.005"]		
.X	±0.20 [.008"]		
X	±0.50 [.019"]		
.X°	±1°		
X°	±2°		



TITLE			
SMP STRAIGHT MALE BULKHEAD SHROUD SOLDER-IN HERMETIC SEAL, SMOOTH BORE			
VIEW		PART NO.	
		ANO 9311-5023	
SIZE	SCALE	SHEET	REV.
A3	10:1	1/1	B