

4 3 2 1

MATERIAL & FINISH

- 1 BODY: BRASS, ALBALOY PLATED
- 2 CENTER CONTACT: BERYLLIUM COPPER ALLOY, SILVER PLATED
- 3 INSULATOR: PTFE
- 4 COUPLING NUT: BRASS, ALBALOY PLATED
- 5 GASKET: SILICONE

ENVIRONMENTAL DATA:

- 1 TEMPERATURE RANGE: -55°C~+125°C
- 2 2011/65/EU(RoHS) AND 2015/863/(RoHS): COMPLIANT
- 3 1999/45/EC(REACH): COMPLIANT

MECHANICAL DATA:

- 1 MATING CYCLES: ≥100
- 2 RECOMMENDED TORQUE: 1.5 NM (NEX10 SIDE)

ELECTRICAL DATA:

- 1 IMPEDANCE: 50 OHMS
- 2 FREQUENCY RANGE: DC~11 GHZ
- 3 VSWR: 1.03 MAX. AT DC~4 GHZ
1.05 MAX. AT 4 GHZ~6 GHZ
1.10 MAX. AT 6 GHZ~10 GHZ
- 4 INSERTION LOSS: ≤ 0.05 x √F(GHZ) DB
- 5 INSULATION RESISTANCE: ≥ 5GΩ
- 6 CENTER CONTACT RESISTANCE: ≤2.0 MΩ, NEX10 SIDE ≤1.0 MΩ, N SIDE
- 6 OUTER CONTACT RESISTANCE: ≤1.0 MΩ, NEX10 SIDE ≤0.25 MΩ, N SIDE
- 7 INTERMODULATION(3RD ORDER): ≥ 155 DBC (2X43 DBM) AT 0.4~6.0 GHZ
- 8 TEST VOLTAGE: 500V RMS
- 9 RF-LEAKAGE: ≥110 DB AT DC TO 6GHZ
- 10 POWER HANDLING: 100W AT 2.0 GHZ AND 85°C AMBIENT TEMPERATURE

APPLICABLE STANDARDS:

- 1 NEX10 INTERFACE ACCORDING TO: TBD
- 2 N INTERFACE ACCORDING TO: IEC61169-16

REVISIONS			
REV.	DESCRIPTION	DATE	APPROVED
A	INITIAL RELEASE	05/23/19	J. QU

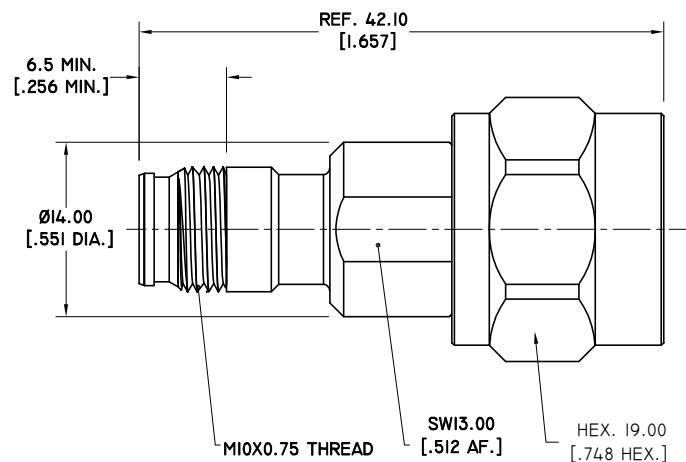

DRAWN	W. YANG	DATE	05/23/19
CHECKED	X. B. YANG	DATE	05/23/19
APPROVED	J. QU	DATE	05/23/19
UNLESS OTHERWISE SPECIFIED DIMENSIONS ARE IN MILLIMETERS, DIMENSIONS IN [] ARE IN INCHES FOR CUSTOMER REFERENCE ONLY UNLESS OTHERWISE SPECIFIED TOLERANCE ARE:		THESE DRAWINGS AND SPECIFICATIONS ARE THE PROPERTY OF ANOISON ELECTRONICS LTD AND SHOULD NOT BE USED WITHOUT WRITTEN PERMISSION COPYRIGHT © 2019 ANOISON ELECTRONICS LTD	
.XX	±0.13 [.005"		
.X	±0.20 [.008"		
X	±0.50 [.019"		
.X°	±1°		
X°	±2°		

TITLE
ADAPTER, M10(NEX10) FEMALE TO N MALE

PART NO.
ANO 742-511-1496

VIEW		SCALE	2.5:1	SHEET	I/I	REV.	A
SIZE	A3						

4 3 2 1