

4

3

2

1

MATERIAL & FINISH:

- 1 BODY: BRASS, ALBALOY PLATED
- 2 OUTER CONTACT: PHOSPHOR BRONZE, SILVER PLATED
- 3 CENTER CONTACT: PHOSPHOR BRONZE, SILVER PLATED
- 4 INSULATOR: PTFE
- 5 COUPLING NUT: BRASS, ALBALOY PLATED
- 6 GASKET: SILICONE RUBBER

ELECTRICAL DATA:

- 1 IMPEDANCE: 50 Ω
- 2 FREQUENCY RANGE: DC-6 GHz
- 3 VSWR: 1.30 MAX.
- 4 PIM: < -155 dBc(2X43 dBm)

ENVIRONMENTAL DATA:

- 1 TEMPERATURE RANGE: -55°C ~ +125°C
- 2 2011/65/EU (RoHS) AND 2015/863/(RoHS): COMPLIANT
- 3 1907/2006/EC (REACH): COMPLIANT

MECHANICAL DATA:

- 1 MATING CYCLES: 100 MIN.
- 2 RECOMMENDED TORQUE: 1.5 NM (M10 SIDE)

REVISIONS

REV.	DESCRIPTION	DATE	APPROVED
A	INITIAL RELEASE	02/14/25	J Q

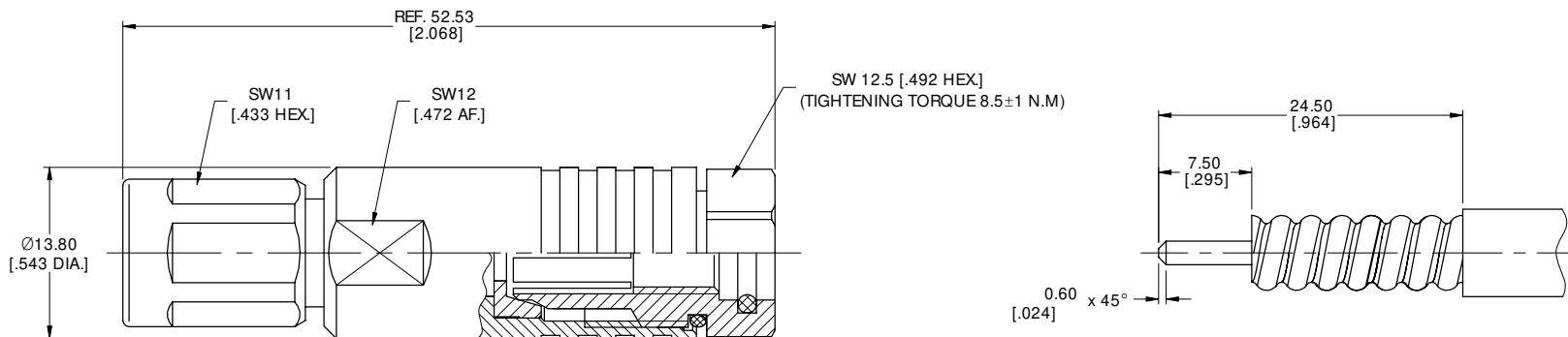

CABLE STRIPPING DIMENSIONS

DRAWN	X. Y	DATE	02/14/25			
CHECKED	W. Y	DATE	02/14/25			
APPROVED	J Q	DATE	02/14/25			
UNLESS OTHERWISE SPECIFIED DIMENSIONS ARE IN MILLIMETERS, DIMENSIONS IN [] ARE IN INCHES FOR CUSTOMER REFERENCE ONLY UNLESS OTHERWISE SPECIFIED TOLERANCE ARE:		THESE DRAWINGS AND SPECIFICATIONS ARE THE PROPERTY OF ANOISON ELECTRONICS LTD AND SHOULD NOT BE USED WITHOUT WRITTEN PERMISSION COPYRIGHT © 2025 ANOISON ELECTRONICS LTD				
	.XX	±0.13 [005"]				
	.X	±0.20 [008"]				
	X	±0.50 [019"]				
	.X°	±1°				
	X°	±2°				
TITLE		M10 MALE STRAIGHT CLAMP FOR 1/4" SUPER FLEX CABLE				
VIEW		PART NO. ANO 7411-2012				
SIZE		A3	SCALE	2.5:1	SHEET	1/1
				REV.	A	

4

3

2

1