

4

3

2

1

REVISIONS			
REV.	DESCRIPTION	DATE	APPROVED
A	INITIAL RELEASE	09/20/16	J. QU

1.0 MATERIAL & FINISH:  
 1.1 BODY: STAINLESS STEEL, PASSIVATED  
 1.2 CENTER CONTACT: BERYLLIUM COPPER ALLOY, GOLD PLATED  
 1.3 SOLDER FERRULE: BRASS, GOLD PLATED  
 1.4 INSULATOR: PEI

2.0 ELECTRICAL DATA:  
 2.1 IMPEDANCE: 50 Ω  
 2.2 FREQUENCY RANGE: DC~50GHZ  
 2.3 VSWR: 1.20 TYP.

3.0 ENVIRONMENTAL DATA:  
 3.1 TEMPERATURE RANGE: -55°C~+135°C  
 3.2 2011/65/EU (RoHS): COMPLIANT

4.0 MECHANICAL DATA:  
 4.1 MECHANICAL DURABILITY: 500 CYCLES  
 4.2 CENTER CONTACT: CAPTIVATED  
 4.3 OUTER CONTACT: SOLDERED

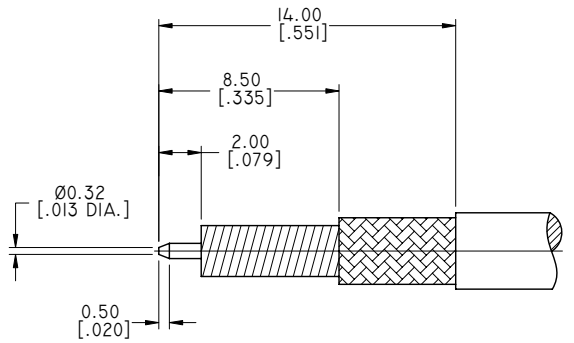
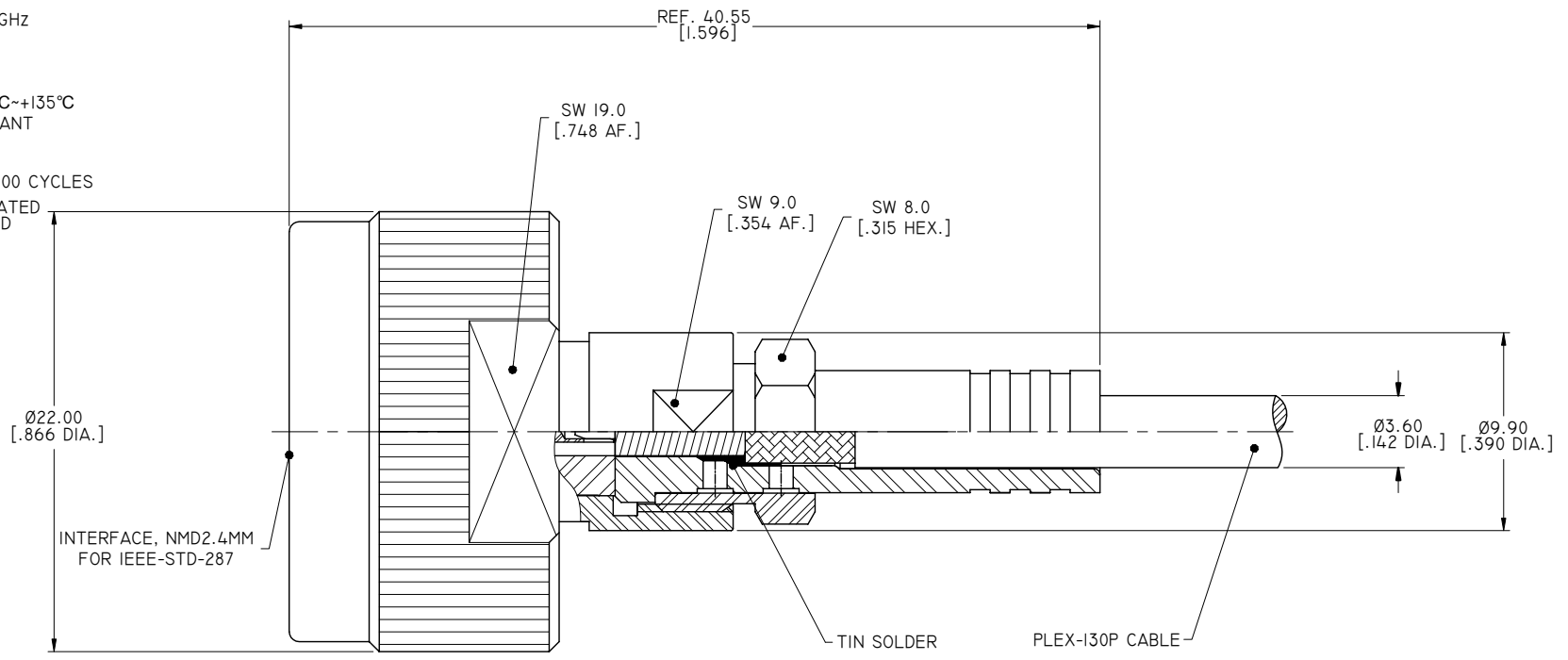

CABLE STRIPPING DIMENSIONS

DRAWN	P. CHEN	DATE	09/20/16
CHECKED	L. YANG	DATE	09/20/16
APPROVED	J. QU	DATE	09/20/16
UNLESS OTHERWISE SPECIFIED DIMENSIONS ARE IN MILLIMETERS. DIMENSIONS IN [ ] ARE IN INCHES FOR CUSTOMER REFERENCE ONLY UNLESS OTHERWISE SPECIFIED TOLERANCE ARE:		THESE DRAWINGS AND SPECIFICATIONS ARE THE PROPERTY OF ANOISON ELECTRONICS LTD AND SHOULD NOT BE USED WITHOUT WRITTEN PERMISSION COPYRIGHT © 2016 ANOISON ELECTRONICS LTD	
.XX	±0.13 [.005"]		
.X	±0.20 [.008"]		
X	±0.50 [.019"]		
.X°	±1°		
X°	±2°		



TITLE  
 NMD2.4MM STRAIGHT FEMALE SOLDER FOR PLEX-I30P CABLE CAPTIVATED CONTACT

VIEW	PART NO. ANO 6812-2008		
SIZE A3	SCALE 4:1	SHEET 1/1	REV. A

4

3

2

1