

4 3 2 1

MATERIAL & FINISH:

- 1 COUPLING NUT: BRASS, NICKEL PLATED
- 2 INSULATOR: PTFE
- 3 GASKET: MVQ(SILICONE RUBBER)
- 4 RETAINING RING: PHOSPHOR BRONZE, NICKEL PLATED
- 5 BODY: BRASS, NICKEL PLATED
- 6 CENTER CONTACT: BRASS, SILVER PLATED
- 7 SOLDER FERRULE: BRASS, GOLD PLATED

ELECTRICAL DATA:

- 1 IMPEDANCE: 50 Ω
- 2 FREQUENCY RANGE: DC~11 GHz
- 3 VSWR: 1.30 MAX.

ENVIRONMENTAL DATA:

- 1 TEMPERATURE RANGE: -55 °C~+125 °C
- 2 2011/65/EU(RoHS) AND 2015/863/(RoHS): COMPLIANT
- 3 1907/2006/EC(REACH): COMPLIANT

REVISIONS			
REV.	DESCRIPTION	DATE	APPROVED
A	INITIAL RELEASE	10/09/21	J QU

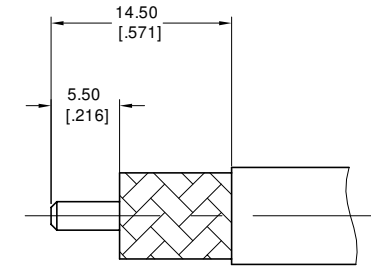
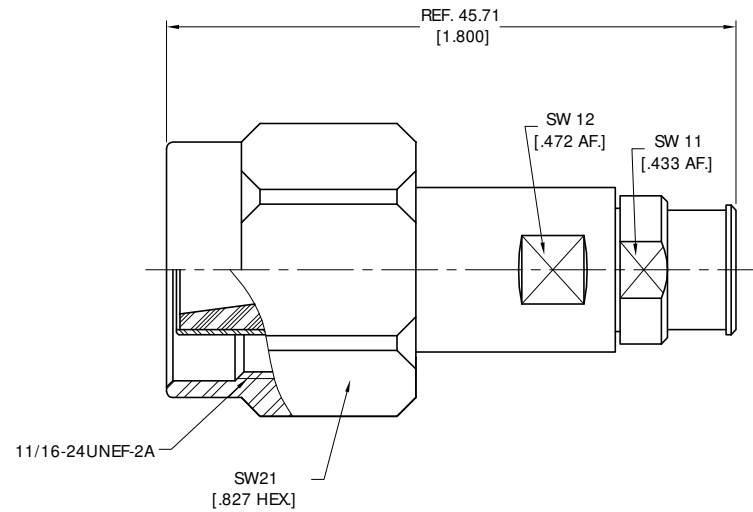

CABLE STRIPPING DIMENSIONS

DRAWN	P. CHEN	DATE	10/09/21
CHECKED	W. YANG	DATE	10/09/21
APPROVED	J QU	DATE	10/09/21
UNLESS OTHERWISE SPECIFIED DIMENSIONS ARE IN MILLIMETERS, DIMENSIONS IN [] ARE IN INCHES FOR CUSTOMER REFERENCE ONLY UNLESS OTHERWISE SPECIFIED TOLERANCE ARE:		THESE DRAWINGS AND SPECIFICATIONS ARE THE PROPERTY OF ANOISON ELECTRONICS LTD AND SHOULD NOT BE USED WITHOUT WRITTEN PERMISSION COPYRIGHT © 2021 ANOISON ELECTRONICS LTD	
XX	±0.13 [.005"]		
.X	±0.20 [.008"]		
X	±0.50 [.019"]		
.X°	±1°		
X°	±2°		



TITLE			
SC STRAIGHT MALE SOLDER FOR IW 2801/GORE 3450/PLEX310 CABLE			
VIEW		PART NO.	
		ANO 5911-2013	
SIZE	SCALE	SHEET	REV.
A3	2.5:1	1/1	A

4 3 2 1