

MATERIAL & FINISH:

- 1 BODY: BRASS, NICKEL PLATED
- 2 OUTER CONTACT: PHOSPHOR BRONZE, NICKEL PLATED
- 3 CENTER CONTACT: PHOSPHOR BRONZE, GOLD PLATED
- 4 COUPLING NUT: BRASS, NICKEL PLATED
- 5 INSULATOR: PTFE
- 6 GASKET: SILICONE RUBBER

ELECTRICAL DATA:

- 1 IMPEDANCE: 50 Ω
- 2 FREQUENCY RANGE: DC~300MHZ

ENVIRONMENTAL DATA:

- 1 TEMPERATURE RANGE: -55°C~+125°C
- 2 2011/65/EU(RoHS) AND 2015/863/(RoHS): COMPLIANT
- 3 1907/2006/EC(REACH) AND 1999/45/EC(REACH): COMPLIANT

REVISIONS			
REV.	DESCRIPTION	DATE	APPROVED
A	INITIAL RELEASE	05/25/10	J. QU
B	DRAWING FORMAT CHANGED	09/03/19	J. QU

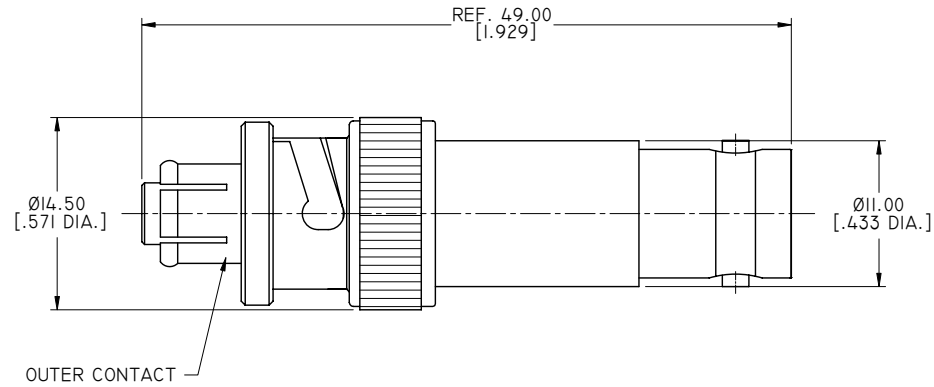

DRAWN	X. B. YANG	DATE	09/03/19
CHECKED	W. YANG	DATE	09/03/19
APPROVED	J. QU	DATE	09/03/19
UNLESS OTHERWISE SPECIFIED DIMENSIONS ARE IN MILLIMETERS. DIMENSIONS IN [] ARE IN INCHES FOR CUSTOMER REFERENCE ONLY UNLESS OTHERWISE SPECIFIED TOLERANCE ARE:		THESE DRAWINGS AND SPECIFICATIONS ARE THE PROPERTY OF ANOISON ELECTRONICS LTD AND SHOULD NOT BE USED WITHOUT WRITTEN PERMISSION COPYRIGHT © 2019 ANOISON ELECTRONICS LTD	
.XX	±0.13 [.005"]		
.X	±0.20 [.008"]		
X	±0.50 [.019"]		
.X°	±1°		
X°	±2°		



TITLE			
ADAPTER, SHV MALE TO SHV FEMALE			
VIEW	PART NO.		
	ANO 571-572-1085		
SIZE	SCALE	SHEET	REV.
A3	2.5:1	I/1	B