

MATERIAL

- 1. BODY: BRASS
- 2. CENTER CONTACT: BRASS
- 3. INSULATOR: PTFE
- 4. UNLOCK SLEEVE: BRASS

FINISH:

- 1. BODY: ALBALOY
- 2. CENTER CONTACT: GOLD
- 3. UNLOCK SLEEVE: NICKEL

ENVIRONMENTAL DATA:

- 1. TEMPERATURE RANGE: -55°C~+125°C
- 2. 2002/95/EC (RoHS): COMPLIANT

ELECTRICAL SPECIFICATIONS:

- 1. IMPEDANCE: 50 Ω
- 2. FREQUENCY RANGE: DC~18GHZ
- 3. VSWR: ≤1.30 AT DC~6GHZ

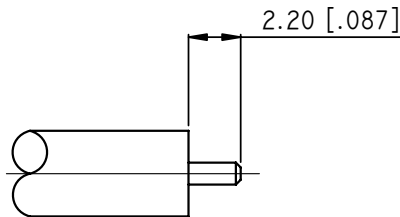
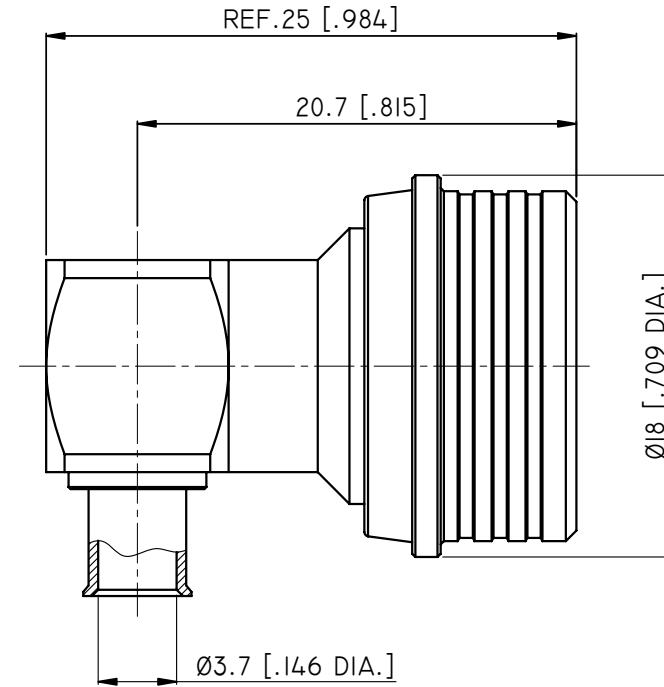
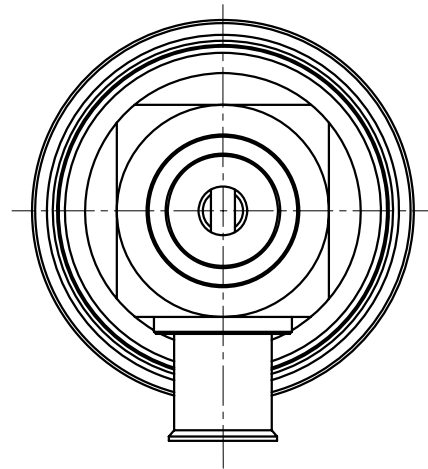

RECOMMENDED CABLE STRIPPING DIM

REVISIONS			
REV.	DESCRIPTION	DATE	APPROVED
A	INITIAL RELEASE	02/06/12	J. QU
B	OUTLINE DRAWING CHANGED	08/07/13	J. QU

DRAWN	H. ZHANG	DATE	08/07/13				
CHECKED	L. YANG	DATE	08/07/13				
APPROVED	J. QU	DATE	08/07/13				
UNLESS OTHERWISE SPECIFIED DIMENSIONS ARE IN MILLIMETERS, DIMENSIONS IN [] ARE IN INCHES FOR CUSTOMER REFERENCE ONLY UNLESS OTHERWISE SPECIFIED TOLERANCE ARE: .XX ±0.13 [.005"] .X ±0.20 [.008"] X ±0.50 [.019"] .X° ±1° X° ±2°				THESE DRAWINGS AND SPECIFICATIONS ARE THE PROPERTY OF ANOISON ELECTRONICS LTD AND SHOULD NOT BE USED WITHOUT WRITTEN PERMISSION COPYRIGHT © 2013 ANOISON ELECTRONICS LTD			
				TITLE HPQN RIGHT ANGLE MALE SOLDER FOR .141 CABLE			
				VIEW 			
				PART NO. ANO 5321-2011			
		SIZE	SCALE	SHEET	REV.		
		A3	4:1	1/1	B		