

**MATERIAL & FINISH:**

1. BODY: BRASS, ALBALOY PLATED
2. CENTER CONTACT: BRASS, GOLD PLATED
3. INSULATOR: PTFE
4. UNLOCK SLEEVE: BRASS, NICKEL PLATED

**ENVIRONMENTAL DATA:**

1. TEMPERATURE RANGE: -55°C~+125°C
2. 2002/95/EC (RoHS): COMPLIANT

**ELECTRICAL SPECIFICATIONS:**

1. IMPEDANCE: 50 Ω
2. FREQUENCY RANGE: DC~6GHZ
3. VSWR: 1.25 MAX

REVISIONS			
REV.	DESCRIPTION	DATE	APPROVED
A	INITIAL RELEASE	07/14/12	J. QU
B	OUTLINE CHANGED	08/07/13	J. QU

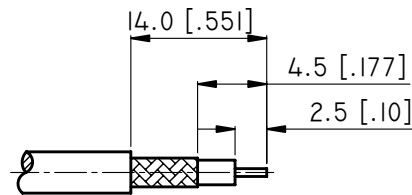
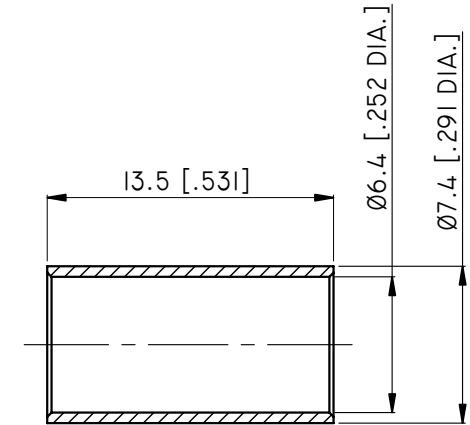
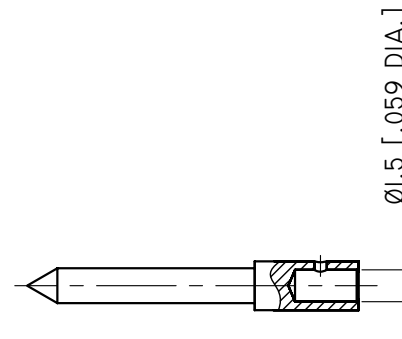
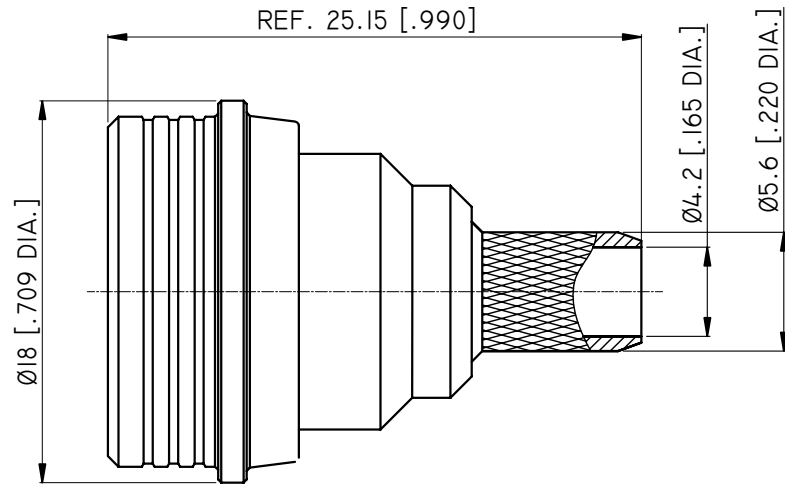

CABLE STRIPPING DIMENSIONS

HEX. CRIMP TOOL

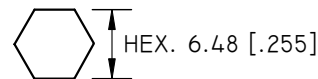

CRIMP WIDTH: 11.0 [.433]

DRAWN	H. ZHANG	DATE	08/07/13				
CHECKED	X. B. YANG	DATE	08/07/13				
APPROVED	J. QU	DATE	08/07/13				
<small>UNLESS OTHERWISE SPECIFIED DIMENSIONS ARE IN MILLINETERS, DIMENSIONS IN [ ] ARE IN INCHES FOR CUSTOMER REFERENCE ONLY UNLESS OTHERWISE SPECIFIED TOLERANCE ARE:</small>				<small>THESE DRAWINGS AND SPECIFICATIONS ARE THE PROPERTY OF ANOISON ELECTRONICS LTD AND SHOULD NOT BE USED WITHOUT WRITTEN PERMISSION COPYRIGHT © 2013 ANOISON ELECTRONICS LTD</small>			
				TITLE			
				HPQN STRAIGHT MALE CRIMP FOR LMR240			
				VIEW		PART NO.	
						ANO 5311-2021	
		SIZE	SCALE	SHEET	REV.		
		A3	4:1	1/1	B		