

MATERIAL & FINISH:

1. BODY: BRASS, NICKEL PLATED
2. CENTER CONTACT: PHOSPHOR BRONZE, GOLD PLATED
3. INSULATOR: PTFE
4. WASHER: PHOSPHOR BRONZE, NICKEL PLATED
5. CRIMP FERRULE: COPPER, NICKEL PLATED
6. FASTENING NUT: BRASS, NICKEL PLATED
7. O-RING: MVQ(SILICONE RUBBER)

ENVIRONMENTAL DATA:

- 1 OPERATING TEMPERATURE: -55°C~+125°C
- 2 2011/65/EU (RoHS): COMPLIANT

ELECTRICAL DATA:

- 1 IMPEDANCE: 50 OHMS
- 2 FREQUENCY RANGE: DC~6 GHz
- 3 VSWR: 1.25 MAX.

REVISIONS			
REV.	DESCRIPTION	DATE	APPROVED
A	INITIAL RELEASE	03/03/15	J. QU
B	VSWR CHANGED	08/28/17	J. QU

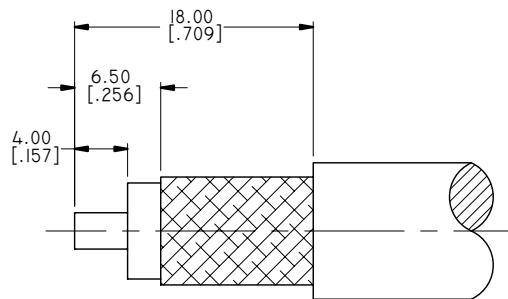
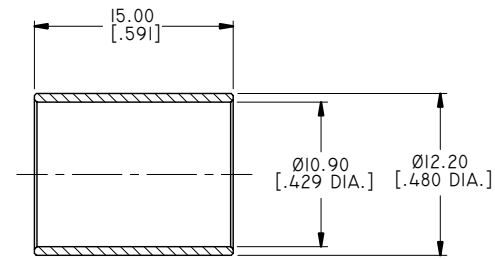
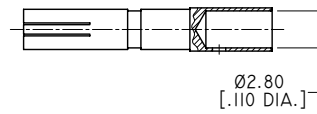
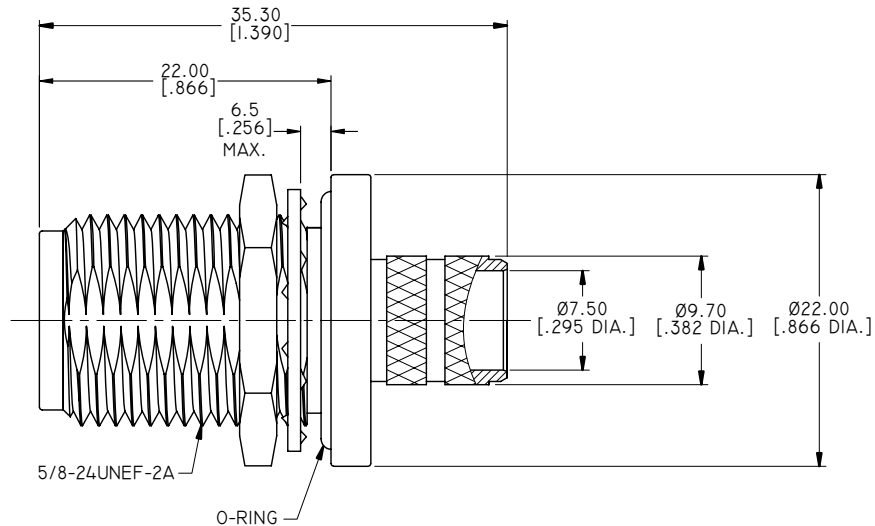

CABLE STRIPPING DIMENSIONS

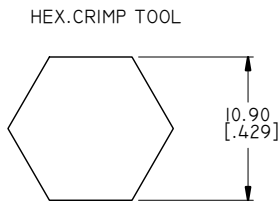

CRIMP WIDTH: 12.0 [.472]

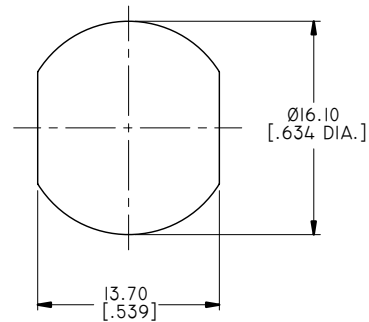

RECOMMENDED PANEL MOUNTING HOLE

DRAWN	X. B. YANG	DATE	08/28/17
CHECKED	P. CHEN	DATE	08/28/17
APPROVED	J. QU	DATE	08/28/17
UNLESS OTHERWISE SPECIFIED DIMENSIONS ARE IN MILLIMETERS. DIMENSIONS IN [ ] ARE IN INCHES FOR CUSTOMER REFERENCE ONLY UNLESS OTHERWISE SPECIFIED TOLERANCE ARE:		THESE DRAWINGS AND SPECIFICATIONS ARE THE PROPERTY OF ANOISON ELECTRONICS LTD AND SHOULD NOT BE USED WITHOUT WRITTEN PERMISSION COPYRIGHT © 2017 ANOISON ELECTRONICS LTD	
.XX	±0.08 [.003"]		
.X	±0.20 [.008"]		
X	±0.50 [.019"]		
.X°	±1°		
X°	±2°		



TITLE  
N STRAIGHT FEMALE BULKHEAD WATERPROOF CRIMP FOR LMR400 CABLE

VIEW	PART NO. ANO 5112-1211		
SIZE A3	SCALE 2.5:1	SHEET 1/1	REV. B