

4

3

2

1

MATERIAL & FINISH:

- 1 BODY: BRASS, NICKEL PLATED
- 2 CENTER CONTACT: BRASS, GOLD PLATED
- 3 INSULATOR: PTFE
- 4 COUPLING NUT: BRASS, NICKEL PLATED
- 5 RETAINING RING: PHOSPHOR BRONZE
- 6 GASKET: SILICONE RUBBER

ELECTRICAL SPECIFICATIONS:

- 1 IMPEDANCE: 50 Ω
- 2 FREQUENCY RANGE: DC~11GHZ
- 3 VSWR: 1.25 MAX.
- 4 INSULATION RESISTANCE: 5000 MΩ
- 5 DIELECTRIC WITHSTANDING VOLTAGE: 1000 V

ENVIRONMENTAL DATA:

- 1 TEMPERATURE RANGE: -55°C~+125°C
- 2 2011/65/EU (RoHS): COMPLIANT

REVISIONS			
REV.	DESCRIPTION	DATE	APPROVED
A	INITIAL RELEASE	06/12/17	J. QU

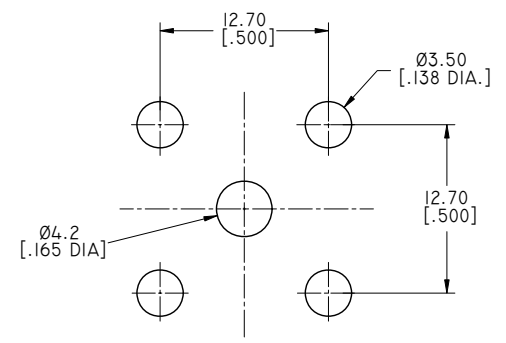
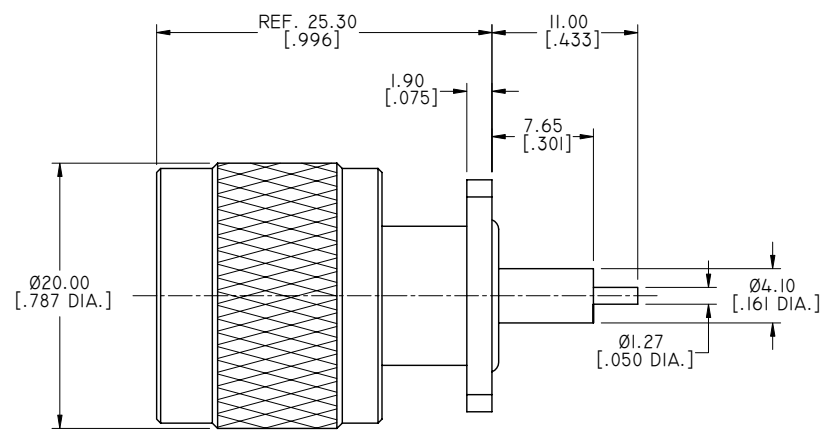
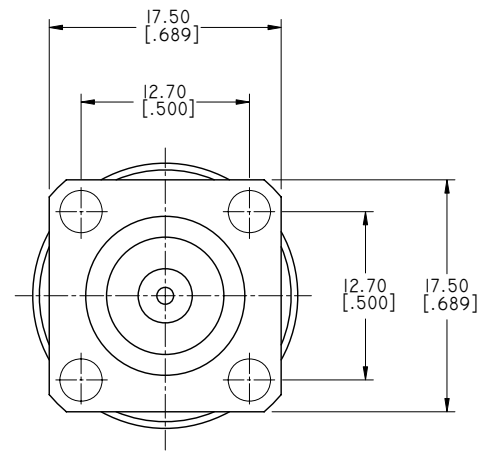

RECOMMENDE MOUNTING HOLE

DRAWN	X. B. YANG	DATE	06/12/17
CHECKED	W. YANG	DATE	06/12/17
APPROVED	J. QU	DATE	06/12/17
UNLESS OTHERWISE SPECIFIED DIMENSIONS ARE IN MILLIMETERS. DIMENSIONS IN [] ARE IN INCHES FOR CUSTOMER REFERENCE ONLY UNLESS OTHERWISE SPECIFIED TOLERANCE ARE:		THESE DRAWINGS AND SPECIFICATIONS ARE THE PROPERTY OF ANOISON ELECTRONICS LTD AND SHOULD NOT BE USED WITHOUT WRITTEN PERMISSION COPYRIGHT © 2017 ANOISON ELECTRONICS LTD	
.XXX	±0.15 [.006"]		
.XX	±0.25 [.01"]		
.X	±0.50 [.019"]		
.X°	±1°		
X°	±2°		



TITLE			
N MALE, 1/2 INCH SQUARE 4 HOLE FLANGE EXTENDED DIELECTRIC			
VIEW		PART NO.	
		ANO 5111-3285	
SIZE	SCALE	SHEET	REV.
A3	2.5:1	1/1	A

4

3

2

1