

**MATERIAL & FINISH:**

- 1 BODY: BRASS, ALBALOY PLATED
- 2 CENTER CONTACT: PHOSPHOR BRONZE, SILVER PLATED
- 3 INSULATOR: PTFE
- 4 COUPLING NUT: BRASS, ALBALOY PLATED

**ENVIRONMENTAL DATA:**

- 1 TEMPERATURE RANGE: -65°C ~ +125°C
- 2 2011/65/EU (RoHS): COMPLIANT

**ELECTRICAL DATA:**

- 1 IMPEDANCE: 50 Ω
- 2 FREQUENCY RANGE: DC~6 GHz
- 3 VSWR: ≤1.20 AT DC~3 GHz  
≤1.30 AT 3~6 GHz
- 4 PIM: < -160 dBc(2X43 dBm)

REVISIONS			
REV.	DESCRIPTION	DATE	APPROVED
A	INITIAL RELEASE	11/16/15	J. Q
B	TIGHTENING TORQUE CHANGED	02/24/16	J. Q
C	PIM: < -160 dBc(2X43 dBm) ADDED	02/14/25	J. Q

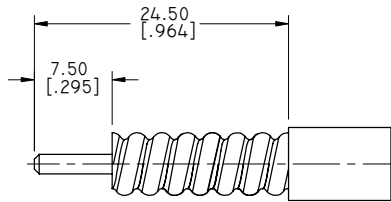
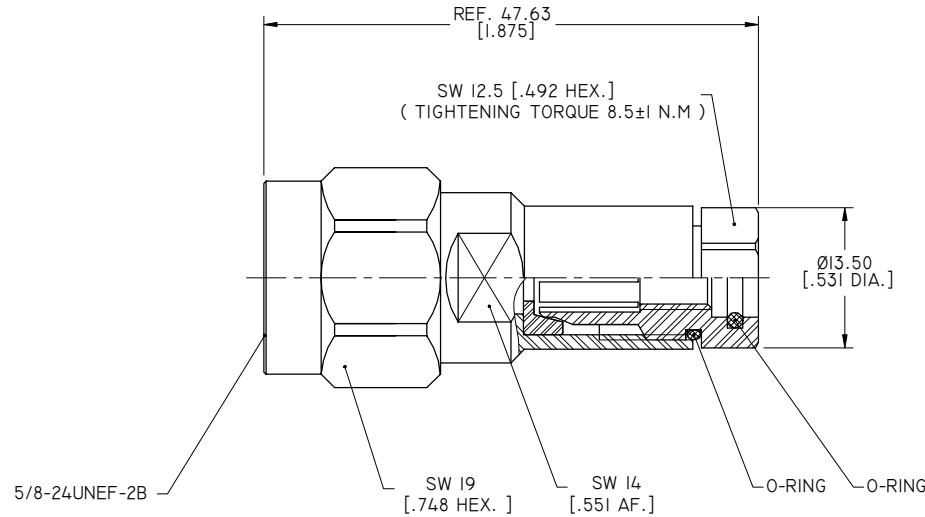

CABLE STRIPPING DIMENSIONS

DRAWN	X. Y	DATE	02/14/25
CHECKED	P. C	DATE	02/14/25
APPROVED	J. Q	DATE	02/14/25

UNLESS OTHERWISE SPECIFIED DIMENSIONS ARE IN MILLIMETERS, DIMENSIONS IN [ ] ARE IN INCHES FOR CUSTOMER REFERENCE ONLY UNLESS OTHERWISE SPECIFIED TOLERANCE ARE:

.XX	±0.13 [.005"]
.X	±0.20 [.008"]
X	±0.50 [.019"]
.X°	±1°
X°	±2°

THESE DRAWINGS AND SPECIFICATIONS ARE THE PROPERTY OF ANOISON ELECTRONICS LTD AND SHOULD NOT BE USED WITHOUT WRITTEN PERMISSION COPYRIGHT © 2025 ANOISON ELECTRONICS LTD



TITLE  
N MALE STRAIGHT CLAMP FOR 1/4" SUPER FLEX CABLE

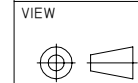

PART NO. ANO 5111-2236			
SIZE A3	SCALE 2:1	SHEET 1/1	REV. C