

MATERIAL & FINISH

- 1 BODY: BRASS, ALBALOY PLATED
- 2 CENTER CONTACT: PHOSPHOR BRONZE, SILVER PLATED
- 3 INSULATOR: PTFE
- 4 COUPLING NUT: BRASS, ALBALOY PLATED
- 5 GASKTE: MVQ(SILICONE RUBBER)

ENVIRONMENTAL DATA:

- 1 TEMPERATURE RANGE: -55°C~+125°C
- 2 2011/65/EU (RoHS): COMPLIANT

ELECTRICAL DATA:

- 1 IMPEDANCE: 50 OHMS
- 2 FREQUENCY RANGE: DC~7.5 GHZ
- 3 VSWR: 1.10 MAX. AT DC~6 GHZ
- 4 WITHSTANDING VOLTAGE: 2500 VRMS MIN.
- 5 INTERMODULATION(3RD ORDER): <-166 DBC(2X43 DBM) AT 0.4~4 GHZ

APPLICABLE STANDARDS:

- 1 4.3-10 INTERFACE ACCORDING TO: IEC61169-54
- 2 7/16 INTERFACE ACCORDING TO: IEC61169-4

REVISIONS			
REV.	DESCRIPTION	DATE	APPROVED
A	INITIAL RELEASE	07/17/15	J. QU
B	VSWR CHANGED	08/29/15	J. QU
C	PROFILE CHANGED	10/22/16	J. QU

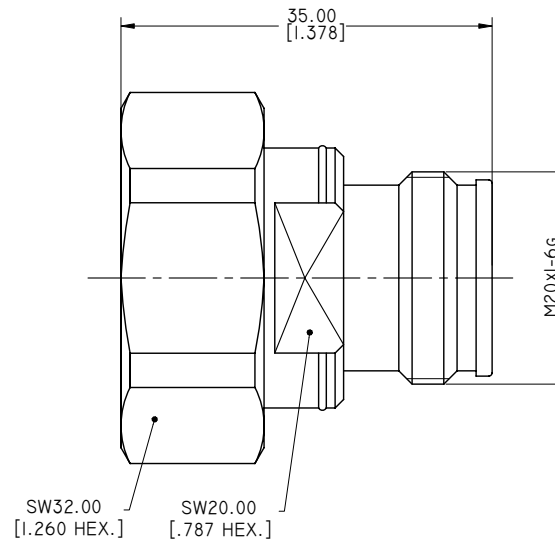

<table border="0"> <tr> <td>DRAWN</td> <td>W. YANG</td> <td>DATE</td> <td>10/22/16</td> </tr> <tr> <td>CHECKED</td> <td>L. YANG</td> <td>DATE</td> <td>10/22/16</td> </tr> <tr> <td>APPROVED</td> <td>J. QU</td> <td>DATE</td> <td>10/22/16</td> </tr> </table>	DRAWN	W. YANG	DATE	10/22/16	CHECKED	L. YANG	DATE	10/22/16	APPROVED	J. QU	DATE	10/22/16	
DRAWN	W. YANG	DATE	10/22/16										
CHECKED	L. YANG	DATE	10/22/16										
APPROVED	J. QU	DATE	10/22/16										
<p>UNLESS OTHERWISE SPECIFIED DIMENSIONS ARE IN MILLIMETERS. DIMENSIONS IN [] ARE IN INCHES FOR CUSTOMER REFERENCE ONLY UNLESS OTHERWISE SPECIFIED TOLERANCE ARE:</p> <table border="0"> <tr> <td>.XX</td> <td>±0.13 [.005"</td> </tr> <tr> <td>.X</td> <td>±0.20 [.008"</td> </tr> <tr> <td>X</td> <td>±0.50 [.019"</td> </tr> <tr> <td>.X°</td> <td>±1°</td> </tr> <tr> <td>X°</td> <td>±2°</td> </tr> </table>	.XX	±0.13 [.005"	.X	±0.20 [.008"	X	±0.50 [.019"	.X°	±1°	X°	±2°	<p>THESE DRAWINGS AND SPECIFICATIONS ARE THE PROPERTY OF ANOISON ELECTRONICS LTD AND SHOULD NOT BE USED WITHOUT WRITTEN PERMISSION COPYRIGHT © 2016 ANOISON ELECTRONICS LTD</p>		
.XX	±0.13 [.005"												
.X	±0.20 [.008"												
X	±0.50 [.019"												
.X°	±1°												
X°	±2°												
<p>TITLE ADAPTER, 4.3-10 FEMALE TO 7/16 MALE</p>		<p>VIEW </p>	<p>PART NO. ANO 472-561-1316</p>										
<table border="0"> <tr> <td>SIZE</td> <td>A3</td> <td>SCALE</td> <td>2:1</td> <td>SHEET</td> <td>1/1</td> <td>REV.</td> <td>B</td> </tr> </table>	SIZE	A3	SCALE	2:1	SHEET	1/1	REV.	B					
SIZE	A3	SCALE	2:1	SHEET	1/1	REV.	B						