

4

3

2

1

MATERIAL & FINISH:

- 1 BODY: BRASS, ALBALOY PLATED
- 2 CENTER CONTACT: BRASS, SILVER PLATED
- 3 COUPLING NUT: BRASS, ALBALOY PLATED
- 4 INSULATOR: PEI
- 5 GASKET: SILICONE RUBBER

ENVIRONMENTAL DATA:

- 1 TEMPERATURE RANGE: -55°C~+125°C
- 2 2011/65/EU (RoHS): COMPLIANT

ELECTRICAL DATA:

- 1 IMPEDANCE: 50 OHMS
- 2 FREQUENCY RANGE: DC~12 GHZ
- 3 VSWR: 1.10 MAX. AT DC~6 GHZ
- 4 WITHSTANDING VOLTAGE: 2500 VRMS MIN.
- 5 INTERMODULATION(3RD ORDER): <-166 DBC(2X4.3 DBM) AT 0.4~4 GHZ

APPLICABLE STANDARDS:

- 1 4.3-10 INTERFACE ACCORDING TO: IEC61169-54
- 2 N INTERFACE ACCORDING TO: IEC61169-16

REVISIONS			
REV.	DESCRIPTION	DATE	APPROVED
A	INITIAL RELEASE	12/29/15	J. QU

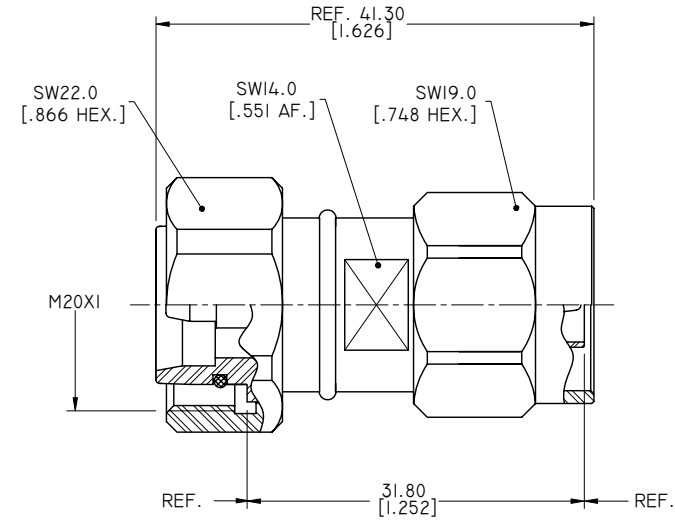

DRAWN	X. B. YANG	DATE	12/29/15
CHECKED	L. YANG	DATE	12/29/15
APPROVED	J. QU	DATE	12/29/15
UNLESS OTHERWISE SPECIFIED DIMENSIONS ARE IN MILLIMETERS, DIMENSIONS IN [] ARE IN INCHES FOR CUSTOMER REFERENCE ONLY UNLESS OTHERWISE SPECIFIED TOLERANCE ARE:		THESE DRAWINGS AND SPECIFICATIONS ARE THE PROPERTY OF ANOISON ELECTRONICS LTD AND SHOULD NOT BE USED WITHOUT WRITTEN PERMISSION COPYRIGHT © 2015 ANOISON ELECTRONICS LTD	
.XX	±0.13 [.005"]		
.X	±0.20 [.008"]		
X	±0.50 [.019"]		
.X°	±1°		
X°	±2°		



TITLE			
ADAPTER, 4.3-10 MALE(SCREW TYPE) TO N MALE			
VIEW		PART NO.	
		ANO 471-511-1357	
SIZE	SCALE	SHEET	REV.
A3	2:1	1/1	A

4

3

2

1