

MATERIAL & FINISH

- 1. BODY: BRASS, NICKEL PLATED
- 2. CENTER CONTACT: PHOSPHOR BRONZE, GOLD PLATED
- 3. FASTENING NUT: BRASS, NICKEL PLATED
- 4. LOCK WASHER: PHOSPHOR BRONZE, NICKEL PLATED
- 5. INSULATOR: PTFE
- 6. O-RING: MVQ(SILICONE RUBBER)

ENVIRONMENTAL DATA:

- 1. TEMPERATURE RANGE: -45°C~+85°C
- 2. 2011/65/EU (RoHS) AND 2015/863/(RoHS): COMPLIANT
- 3. 1999/45/EC(REACH): COMPLIANT

REVISIONS

REV.	DESCRIPTION	DATE	APPROVED
A	INITIAL RELEASE	02/14/19	J. QU

ELECTRICAL SPECIFICATIONS:

- 1. WORKING VOLTAGE: 800 VRMS
- 2. FREQUENCY RANGE: DC~500 MHZ

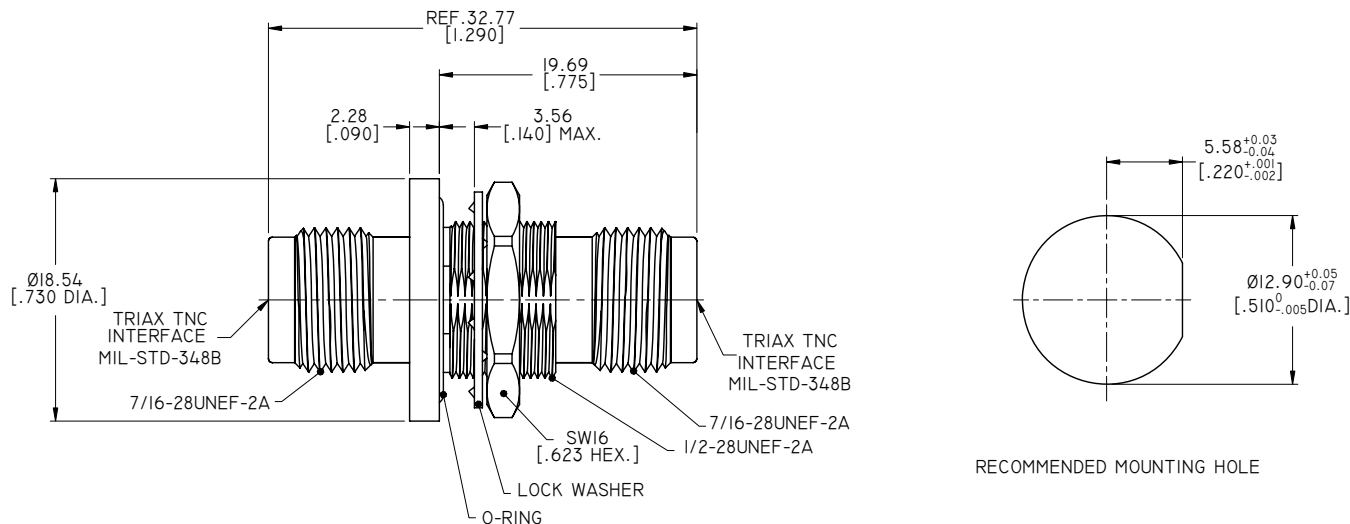

DRAWN	P. CHEN	DATE	02/14/19
CHECKED	L. YANG	DATE	02/14/19
APPROVED	J. QU	DATE	02/14/19

UNLESS OTHERWISE SPECIFIED DIMENSIONS ARE IN MILLIMETERS. DIMENSIONS IN [ ] ARE IN INCHES FOR CUSTOMER REFERENCE ONLY UNLESS OTHERWISE SPECIFIED TOLERANCE ARE:

.XX	±0.13 [.005"]
.X	±0.20 [.008"]
X	±0.50 [.019"]
.X°	±1°
X°	±2°

THESE DRAWINGS AND SPECIFICATIONS ARE THE PROPERTY OF ANOISON ELECTRONICS LTD AND SHOULD NOT BE USED WITHOUT WRITTEN PERMISSION COPYRIGHT © 2019 ANOISON ELECTRONICS LTD



TITLE  
ADAPTER, TRIAX TNC FEMALE TO TRIAX TNC BULKHEAD MOUNT ISOLATED GROUND FEMALE

VIEW	PART NO. ANO 422-422-1483		
SIZE A3	SCALE 2.5:1	SHEET 1/1	REV. A