

MATERIAL & FINISH

- 1 BODY: BRASS, NICKEL PLATED
- 2 CENTER CONTACT: BRASS, GOLD PLATED
- 3 MIDDLE CONTACT: BERYLLIUM COPPER ALLOY, GOLD PLATED
- 4 COUPLING NUT: BRASS, NICKEL PLATED
- 5 INSULATOR: PTFE
- 6 GASKET: SILICONE RUBBER

ELECTRICAL SPECIFICATIONS:

- 1 IMPEDANCE: 75 OHMS \pm 1;
- 2 WORKING VOLTAGE: 400 VRMS
- 3 FREQUENCY RANGE: DC~500 MHZ

ENVIRONMENTAL DATA:

- 1 TEMPERATURE RANGE: -55°C~+125°C
- 2 2011/65/EU(RoHS) AND 2015/863/(RoHS): COMPLIANT
- 3 1999/45/EC(REACH): COMPLIANT

REVISIONS			
REV.	DESCRIPTION	DATE	APPROVED
A	INITIAL RELEASE	07/02/13	J. QU
B	1. DRAWING FORMAT CHANGED 2. 2015/863/(RoHS): COMPLIANT ADDED 3. 1999/45/EC(REACH): COMPLIANT ADDED	10/29/18	J. QU

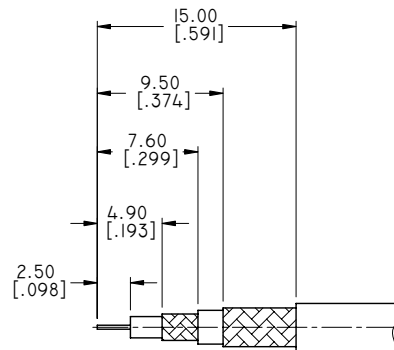
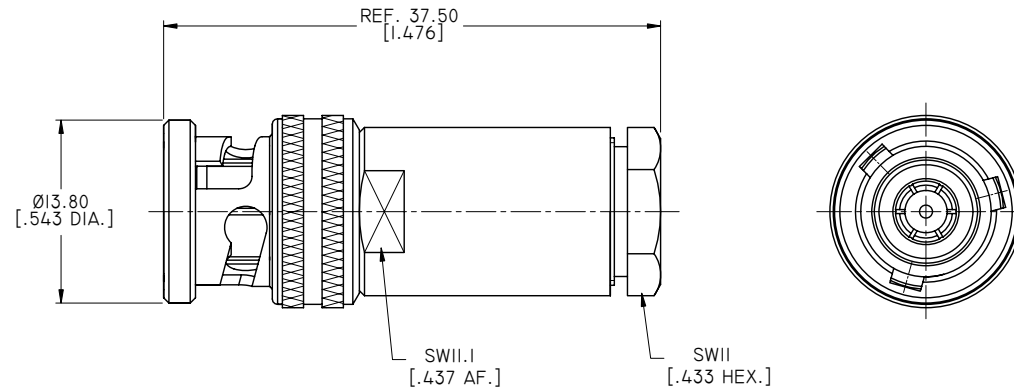

CABLE STRIPPING DIMENSIONS

DRAWN	X. B. YANG	DATE	10/29/18
CHECKED	W. YANG	DATE	10/29/18
APPROVED	J. QU	DATE	10/29/18
UNLESS OTHERWISE SPECIFIED DIMENSIONS ARE IN MILLIMETERS. DIMENSIONS IN [] ARE IN INCHES FOR CUSTOMER REFERENCE ONLY UNLESS OTHERWISE SPECIFIED TOLERANCE ARE:		THESE DRAWINGS AND SPECIFICATIONS ARE THE PROPERTY OF ANOISON ELECTRONICS LTD AND SHOULD NOT BE USED WITHOUT WRITTEN PERMISSION COPYRIGHT © 2018 ANOISON ELECTRONICS LTD	
.XX	±0.13 [.005"]		
.X	±0.20 [.008"]		
X	±0.50 [.019"]		
.X°	±1°		
X°	±2°		



TITLE			
TRIAX BNC MALE CLAMP FOR TRX-I79 CABLE			
VIEW		PART NO.	
		ANO 4211-2004	
SIZE	SCALE	SHEET	REV.
A3	2.5:1	1/1	B