

MATERIAL & FINISH:

- 1 BODY: BRASS, NICKEL PLATED
- 2 CENTER CONTACT: BRASS, GOLD PLATED
- 3 INSULATOR: PTFE
- 4 NUT: BRASS, NICKEL PLATED
- 5 WASHER: PHOSPHOR BRONZE, NICKEL PLATED
- 6 CRIMP FERRULE: COPPER, NICKEL PLATED
- 7 O-RING: MVQ(SILICONE RUBBER)

ENVIRONMENTAL DATA:

- 1 TEMPERATURE RANGE: -65°C ~ +125°C
- 2 2011/65/EU (RoHS): COMPLIANT

ELECTRICAL DATA:

- 1 IMPEDANCE: 50 Ω
- 2 FREQUENCY RANGE: DC~4 GHz
- 3 VSWR: ≤1.30
- 4 WITHSTAND VOLTAGE: 1500V

REVISIONS			
REV.	DESCRIPTION	DATE	APPROVED
A	INITIAL RELEASE	04/07/16	J. QU
B	CHANGED DIMENSION	04/09/16	J. QU

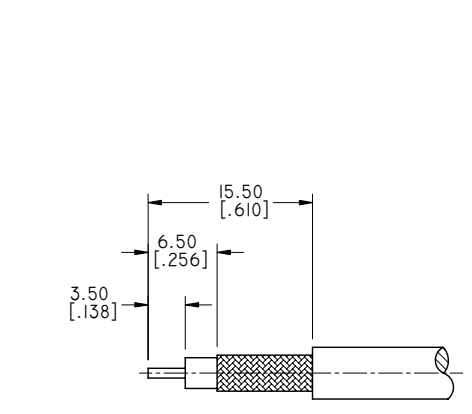
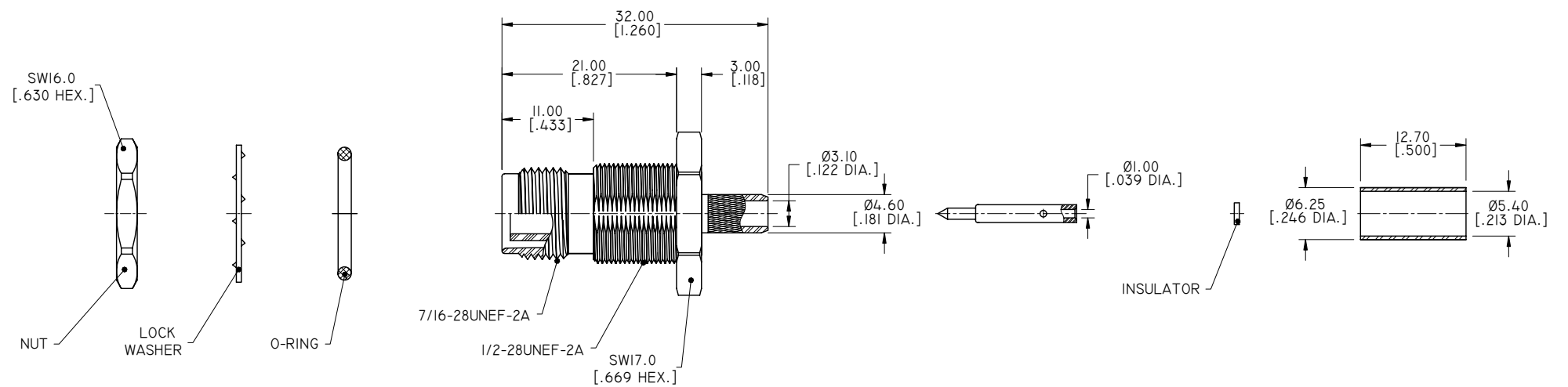

CABLE STRIPPING DIMENSIONS

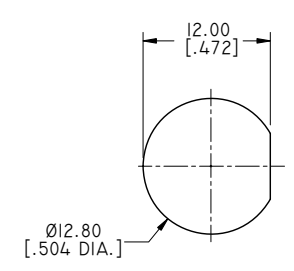

RECOMMENDED MOUNTING HOLE

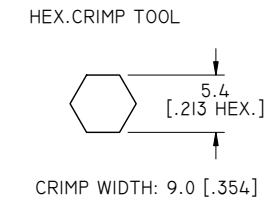

HEX. CRIMP TOOL

CRIMP WIDTH: 9.0 [.354]

DRAWN	P. CHEN	DATE	04/09/16
CHECKED	L. YANG	DATE	04/09/16
APPROVED	J. QU	DATE	04/09/16
UNLESS OTHERWISE SPECIFIED DIMENSIONS ARE IN MILLIMETERS. DIMENSIONS IN [ ] ARE IN INCHES FOR CUSTOMER REFERENCE ONLY UNLESS OTHERWISE SPECIFIED TOLERANCE ARE:		THESE DRAWINGS AND SPECIFICATIONS ARE THE PROPERTY OF ANOISON ELECTRONICS LTD AND SHOULD NOT BE USED WITHOUT WRITTEN PERMISSION COPYRIGHT © 2016 ANOISON ELECTRONICS LTD	
.XX	±0.13 [.005"]		
.X	±0.20 [.008"]		
X	±0.50 [.019"]		
.X°	±1°		
X°	±2°		



TITLE			
RP TNC FEMALE BULKHEAD CRIMP FOR RG58/LMRI95 CABLE			
VIEW		PART NO.	
		ANO 3314-1067	
SIZE	SCALE	SHEET	REV.
A3	2:1	I/1	B