

4

3

2

1

MATERIAL & FINISH:

- 1 BODY: STAINLESS STEEL, PASSIVATED
- 2 CENTER CONTACT: BERYLLIUM COPPER ALLOY, GOLD PLATED
- 3 SOLDER FERRULE: BRASS, GOLD PLATED
- 4 INSULATOR: PTFE

ELECTRICAL DATA:

- 1 IMPEDANCE: 50 Ω
- 2 FREQUENCY RANGE: DC~11 GHz
- 3 VSWR: 1.35 MAX.

ENVIRONMENTAL DATA:

- 1 TEMPERATURE RANGE: -55 °C~+165 °C
- 2 2011/65/EU (RoHS) AND 2015/863/(RoHS): COMPLIANT
- 3 1999/45/EC (REACH): COMPLIANT

REVISIONS			
REV.	DESCRIPTION	DATE	APPROVED
A	INITIAL RELEASE	03/01/21	J QU

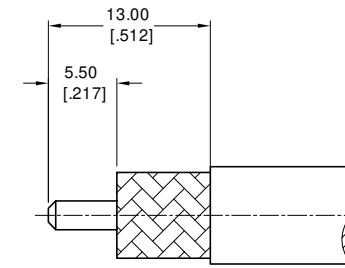
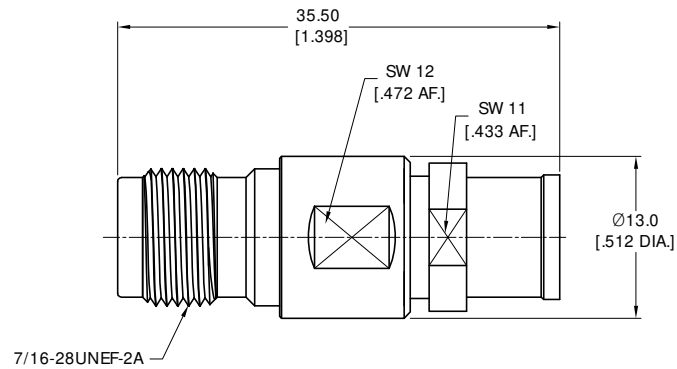

CABLE STRIPPING DIMENSIONS

D

C

B

A

D

C

B

A

DRAWN	P. CHEN	DATE	03/01/21
CHECKED	X. B. YANG	DATE	03/01/21
APPROVED	J QU	DATE	03/01/21
UNLESS OTHERWISE SPECIFIED DIMENSIONS ARE IN MILLIMETERS, DIMENSIONS IN [] ARE IN INCHES FOR CUSTOMER REFERENCE ONLY UNLESS OTHERWISE SPECIFIED TOLERANCE ARE:		THESE DRAWINGS AND SPECIFICATIONS ARE THE PROPERTY OF ANOISON ELECTRONICS LTD AND SHOULD NOT BE USED WITHOUT WRITTEN PERMISSION COPYRIGHT © 2021 ANOISON ELECTRONICS LTD	
XX	±0.13 [0.005"]		
.X	±0.20 [0.008"]		
X	±0.50 [0.019"]		
.X°	±1°		
X°	±2°		

TITLE TNC STRAIGHT FEMALE SOLDER FOR IW 2801/ GORE 3450/PLEX310 CABLE			
VIEW	PART NO. ANO 3312-2109		
	SIZE A3	SCALE 2.5:1	SHEET 1/1
		REV. A	

4

3

2

1