

MATERIAL & FINISH:

- 1 BODY: BRASS, NICKEL PLATED
- 2 CENTER CONTACT: PHOSPHOR BRONZE, GOLD PLATED
- 3 CRIMP FERRULE: COPPER, NICKEL PLATED
- 4 INSULATOR: PTFE

ELECTRICAL DATA:

- 1 IMPEDANCE: 50 Ω
- 2 FREQUENCY RANGE: DC-6 GHz
- 3 VSWR: 1.25 TYP.

ENVIRONMENTAL DATA:

- 1 TEMPERATURE RANGE: -55 °C ~ +85 °C
- 2 2011/65/EU (RoHS) AND 2015/863/(RoHS): COMPLIANT
- 3 1999/45/EC (REACH): COMPLIANT

REVISIONS			
REV.	DESCRIPTION	DATE	APPROVED
A	INITIAL RELEASE	01/06/21	J QU

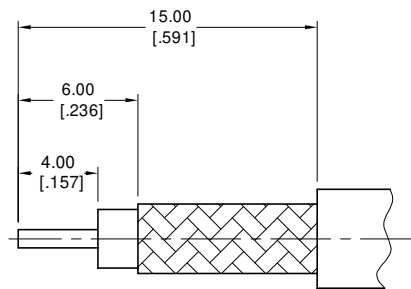
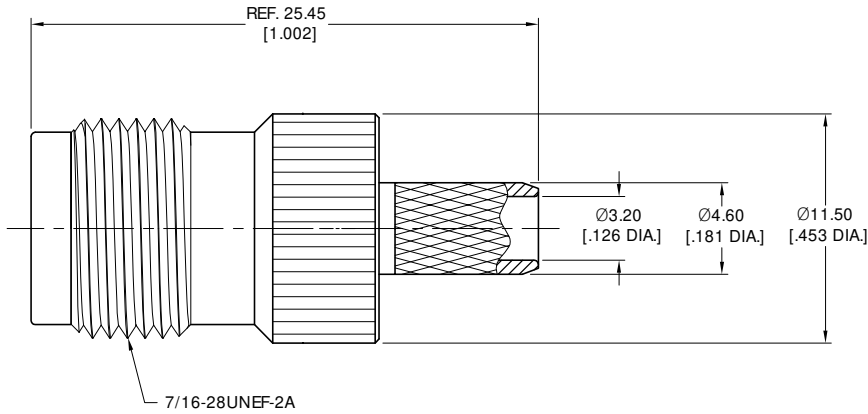

CABLE STRIPPING DIMENSIONS

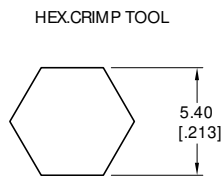

CRIMP WIDTH: 10.0 [.394]

DRAWN	P. CHEN	DATE	01/06/21
CHECKED	X. B. YANG	DATE	01/06/21
APPROVED	J QU	DATE	01/06/21
UNLESS OTHERWISE SPECIFIED DIMENSIONS ARE IN MILLIMETERS, DIMENSIONS IN [] ARE IN INCHES FOR CUSTOMER REFERENCE ONLY UNLESS OTHERWISE SPECIFIED TOLERANCE ARE:		THESE DRAWINGS AND SPECIFICATIONS ARE THE PROPERTY OF ANOISON ELECTRONICS LTD AND SHOULD NOT BE USED WITHOUT WRITTEN PERMISSION COPYRIGHT © 2021 ANOISON ELECTRONICS LTD	
.XX	±0.13 [.005"]		
.X	±0.20 [.008"]		
X	±0.50 [.019"]		
.X°	±1°		
X°	±2°		

TITLE
TNC STRAIGHT FEMALE CRIMP FOR EPI80/LMRI95 CABLE

VIEW

PART NO.
ANO 3312-2092

SIZE A3	SCALE 4:1	SHEET 1/1	REV. A
------------	--------------	--------------	-----------

4

3

2

1

D

D

C

C

B

B

A

A

4

3

2

1