

MATERIAL & FINISH:

- 1 BODY: BRASS, NICKEL PLATED
- 2 CENTER CONTACT: PHOSPHOR BRONZE, GOLD PLATED
- 3 SOLDER FERRULE: BRASS, ALBALOY PLATED
- 4 CRIMP FERRULE: COPPER, NICKEL PLATED
- 5 FASTENING NUT: BRASS, NICKEL PLATED
- 6 LOCK WASHER: PHOSPHOR BRONZE, NICKEL PLATED
- 7 INSULATOR: PTFE

ELECTRICAL DATA:

- 1 IMPEDANCE: 50 Ω
- 2 FREQUENCY RANGE: DC-II GHZ
- 3 INSULATION RESISTANCE: 5000MΩ
- 4 DIELECTRIC WITHSTANDING VOLTAGE: 1000V

ENVIRONMENTAL DATA:

- 1 TEMPERATURE RANGE: -55°C~+125°C
- 2 2011/65/EU (RoHS): COMPLIANT

REVISIONS			
REV.	DESCRIPTION	DATE	APPROVED
A	INITIAL RELEASE	02/10/12	J. QU
B	DRAWING FORMAT CHANGED	08/31/17	J. QU

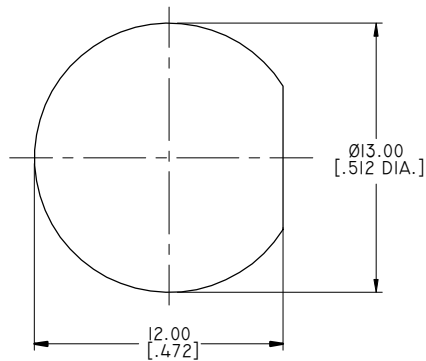
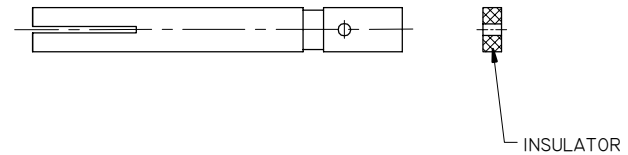
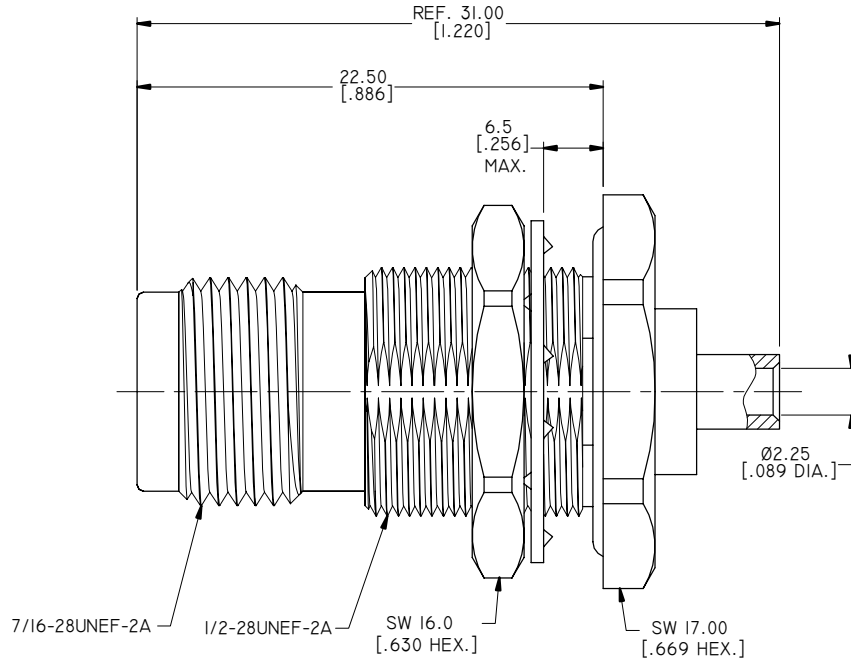

RECOMMENDED MOUNTING HOLE

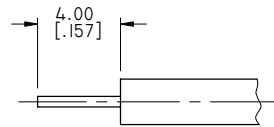

CABLE STRIPPING DIMENSIONS

DRAWN	X. B. YANG	DATE	08/31/17
CHECKED	P. CHEN	DATE	08/31/17
APPROVED	J. QU	DATE	08/31/17
UNLESS OTHERWISE SPECIFIED DIMENSIONS ARE IN MILLINMETERS, DIMENSIONS IN [] ARE IN INCHES FOR CUSTOMER REFERENCE ONLY UNLESS OTHERWISE SPECIFIED TOLERANCE ARE:		THESE DRAWINGS AND SPECIFICATIONS ARE THE PROPERTY OF ANOISON ELECTRONICS LTD AND SHOULD NOT BE USED WITHOUT WRITTEN PERMISSION COPYRIGHT © 2017 ANOISON ELECTRONICS LTD	
.XX	±0.13 [.005"]		
.X	±0.20 [.008"]		
X	±0.50 [.019"]		
.X°	±1°		
X°	±2°		



TITLE
TNC FEMALE BULKHEAD SOLDER FOR .086 CABLE

VIEW	PART NO. ANO 3312-1023		
SIZE	SCALE	SHEET	REV.
A3	4:1	1/1	B