

MATERIAL & FINISH:

- 1 BODY: BRASS, NICKEL PLATED
- 2 CENTER CONTACT: PHOSPHOR BRONZE, GOLD PLATED
- 3 FASTENING NUT: BRASS, NICKEL PLATED
- 4 LOCK WASHER: PHOSPHOR BRONZE, NICKEL PLATED
- 5 INSULATOR: PTFE

ELECTRICAL DATA:

- 1 IMPEDANCE: 50 Ω
- 2 FREQUENCY RANGE: DC~4 GHz
- 3 VSWR: 1.35 MAX.

ENVIRONMENTAL DATA:

- 1 TEMPERATURE RANGE: -55°C~+125°C
- 2 2011/65/EU (RoHS): COMPLIANT

REVISIONS			
REV.	DESCRIPTION	DATE	APPROVED
A	INITIAL RELEASE	08/03/16	J. QU

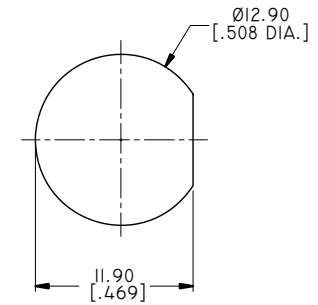
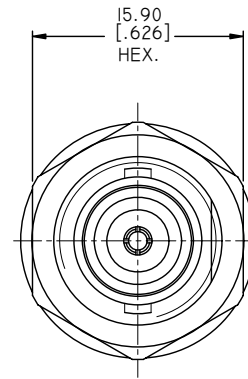
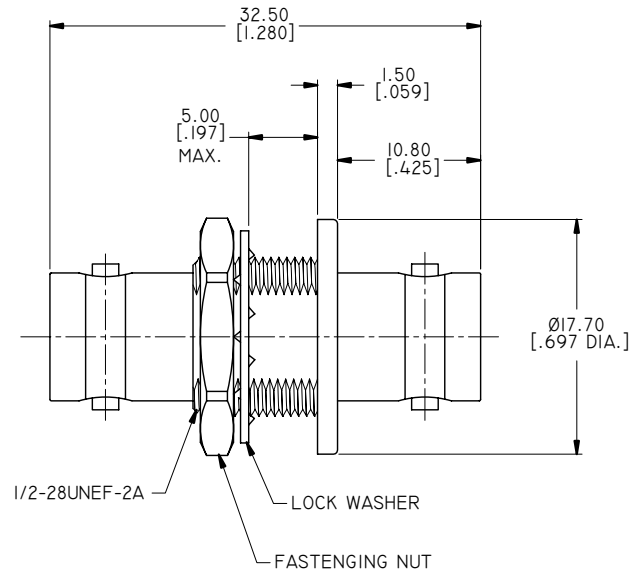

RECOMMENDED MOUNTING HOLE

DRAWN	X. B. YANG	DATE	08/03/16
CHECKED	L. YANG	DATE	08/03/16
APPROVED	J. QU	DATE	08/03/16
UNLESS OTHERWISE SPECIFIED DIMENSIONS ARE IN MILLIMETERS. DIMENSIONS IN [] ARE IN INCHES FOR CUSTOMER REFERENCE ONLY UNLESS OTHERWISE SPECIFIED TOLERANCE ARE:		THESE DRAWINGS AND SPECIFICATIONS ARE THE PROPERTY OF ANOISON ELECTRONICS LTD AND SHOULD NOT BE USED WITHOUT WRITTEN PERMISSION COPYRIGHT © 2016 ANOISON ELECTRONICS LTD	
.XX	±0.13 [.005"]		
.X	±0.20 [.008"]		
X	±0.50 [.019"]		
.X°	±1°		
X°	±2°		



TITLE
ADAPTER, BNC FEMALE BULKHEAD TO BNC FEMALE

VIEW	PART NO. ANO 312-312-1378		
	SIZE A3	SCALE 2.5:1	SHEET 1/1
		REV. A	