

MATERIAL & FINISH:

- 1 BODY: BRASS, NICKEL PLATED
- 2 CENTER CONTACT: PHOSPHOR BRONZE, GOLD PLATED
- 3 FASTENING NUT: BRASS, NICKEL PLATED
- 4 LOCK WASHER: PHOSPHOR BRONZE, NICKEL PLATED
- 5 INSULATOR: PTFE
- 6 GASKET: SILICONE RUBBER

ELECTRICAL DATA:

- 1 IMPEDANCE: 50 OHMS
- 2 FREQUENCY RANGE: DC~4 GHz
- 3 VSWR: 1.35 MAX.

ENVIRONMENTAL DATA:

- 1 TEMPERATURE RANGE: -55°C~+125°C
- 2 2011/65/EU (RoHS) AND 2015/863/(RoHS): COMPLIANT
- 3 1907/2006/EC (REACH): COMPLIANT
- 4 IP GRADE: IP68 (MATED)

REVISIONS			
REV.	DESCRIPTION	DATE	APPROVED
A	INITIAL RELEASE	05/12/22	J QU

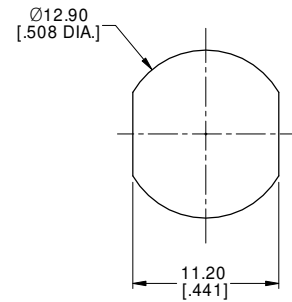
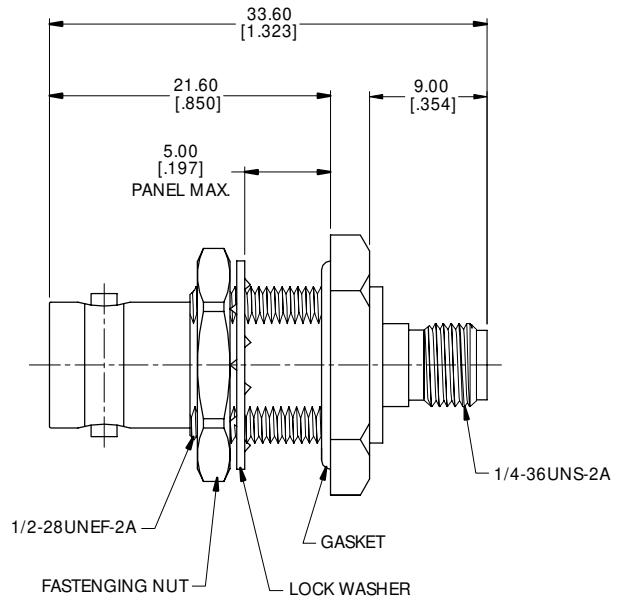
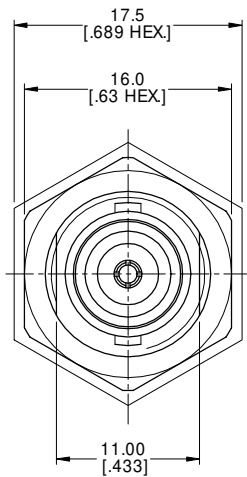

RECOMMENDED MOUNTING HOLE

DRAWN	XB. YANG	DATE	05/12/22
CHECKED	W. YANG	DATE	05/12/22
APPROVED	J QU	DATE	05/12/22

UNLESS OTHERWISE SPECIFIED DIMENSIONS ARE IN MILLIMETERS, DIMENSIONS IN [] ARE IN INCHES FOR CUSTOMER REFERENCE ONLY UNLESS OTHERWISE SPECIFIED TOLERANCE ARE:

.xx	±0.13 [.005"]
.x	±0.20 [.008"]
x	±0.50 [.019"]
xc	±1°
x°	±2°

THESE DRAWINGS AND SPECIFICATIONS ARE THE PROPERTY OF ANOISON ELECTRONICS LTD AND SHOULD NOT BE USED WITHOUT WRITTEN PERMISSION COPYRIGHT © 2022 ANOISON ELECTRONICS LTD



TITLE
ADAPTER, BNC FEMALE TO SMA FEMALE BULKHEAD

VIEW	PART NO. ANO 312-212-1002		
	SIZE A3	SCALE 2.5:1	SHEET 1/1
		REV. A	