

4

3

2

1

MATERIAL & FINISH:

- 1 BODY: STAINLESS STEEL, PASSIVATED
- 2 CENTER CONTACT: BERYLLIUM COPPER ALLOY, GOLD PLATED
- 3 SOLDER FERRULE: BRASS, GOLD PLATED
- 4 COUPLING NUT: STAINLESS STEEL, PASSIVATED
- 5 INSULATOR: PEI

ELECTRICAL DATA:

- 1 IMPEDANCE: 50 Ω
- 2 FREQUENCY RANGE: DC~40 GHz
- 3 VSWR: 1.30 MAX.

ENVIRONMENTAL DATA:

- 1 TEMPERATURE RANGE: -55 °C~+165 °C
- 2 2011/65/EU (RoHS) AND 2015/863/(RoHS): COMPLIANT
- 3 1999/45/EC (REACH): COMPLIANT

REVISIONS			
REV.	DESCRIPTION	DATE	APPROVED
A	INITIAL RELEASE	04/18/22	J QU

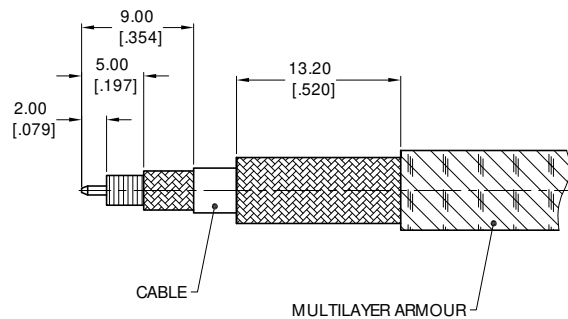
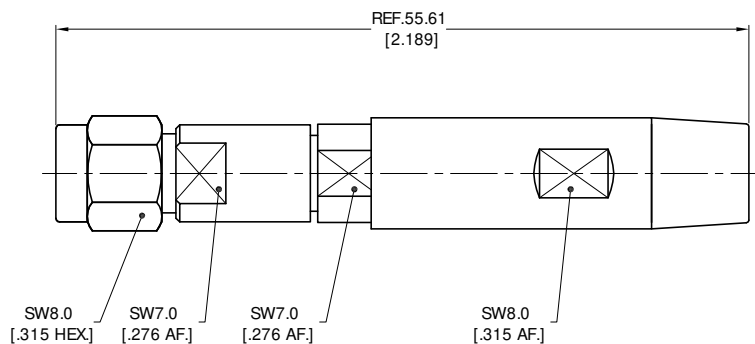

CABLE & MULTILAYER ARMOUR STRIPPING DIMENSIONS

DRAWN	P. CHEN	DATE	04/18/22
CHECKED	X. B. YANG	DATE	04/18/22
APPROVED	J QU	DATE	04/18/22
UNLESS OTHERWISE SPECIFIED DIMENSIONS ARE IN MILLIMETERS, DIMENSIONS IN [] ARE IN INCHES FOR CUSTOMER REFERENCE ONLY UNLESS OTHERWISE SPECIFIED TOLERANCE ARE:		THESE DRAWINGS AND SPECIFICATIONS ARE THE PROPERTY OF ANOISON ELECTRONICS LTD AND SHOULD NOT BE USED WITHOUT WRITTEN PERMISSION COPYRIGHT © 2022 ANOISON ELECTRONICS LTD	
.XX	±0.13 [.005"]		
.X	±0.20 [.008"]		
X	±0.50 [.019"]		
.X°	±1°		
X°	±2°		



TITLE
2.92MM STRAIGHT MALE SOLDER FOR PLEX130P CABLE, CAPTIVATED CONTACT

VIEW	PART NO. ANO 2911-2088-PT			
	SIZE A3	SCALE 2.5:1	SHEET 1/1	REV. A

4

3

2

1