

REVISIONS			
REV.	DESCRIPTION	DATE	APPROVED
A	INITIAL RELEASE	12/16/21	J. QU

MATERIAL & FINISH:

- 1 BODY: STAINLESS STEEL, PASSIVATED
- 2 CENTER CONTACT: BERYLLIUM COPPER ALLOY, GOLD PLATED
- 3 INSULATOR: PEI
- 4 COUPLING NUT: STAINLESS STEEL, PASSIVATED
- 5 RADIATOR: ALUMINIUM, BLACK

ELECTRICAL DATA:

- 1 IMPEDANCE: 50 Ω
- 2 FREQUENCY RANGE: DC~40 GHZ
- 3 VSWR: 1.26 MAX.
- 4 AVERAGE POWER: 15W ON THE LEFT OR 10W ON THE RIGHT CORRESPONDS TO AN AMBIENT TEMPERATURE OF 25°C. WHEN THE AMBIENT TEMPERATURE RISE TO 100°C, THE POWER LINEARLY DECREASES TO 1.5W OR 1W
- 5 PEAK POWER: MAXIMUM POWER 200 W (5μS PULSE WIDTH WITH THE MAXIMUM 4% DUTY CYCLE)
- 6 WORKING TIME: NO AIR COOLING, ≤5 MINUTES, COOLING TO BELOW 30°C CAN BE USED AGAIN; WHEN THERE IS AIR COOLING, AIR VOLUME ≥8CFM, LONG-TERM WORK
- 7 ATTENUATOR ACCURACY: SEE TABLE

ENVIRONMENTAL DATA:

- 1 TEMPERATURE RANGE: -55°C~+100°C
- 2 2011/65/EU(RoHS) AND 2015/863/(RoHS): COMPLIANT
- 3 1907/2006/EC(REACH) AND 1999/45/EC(REACH): COMPLIANT

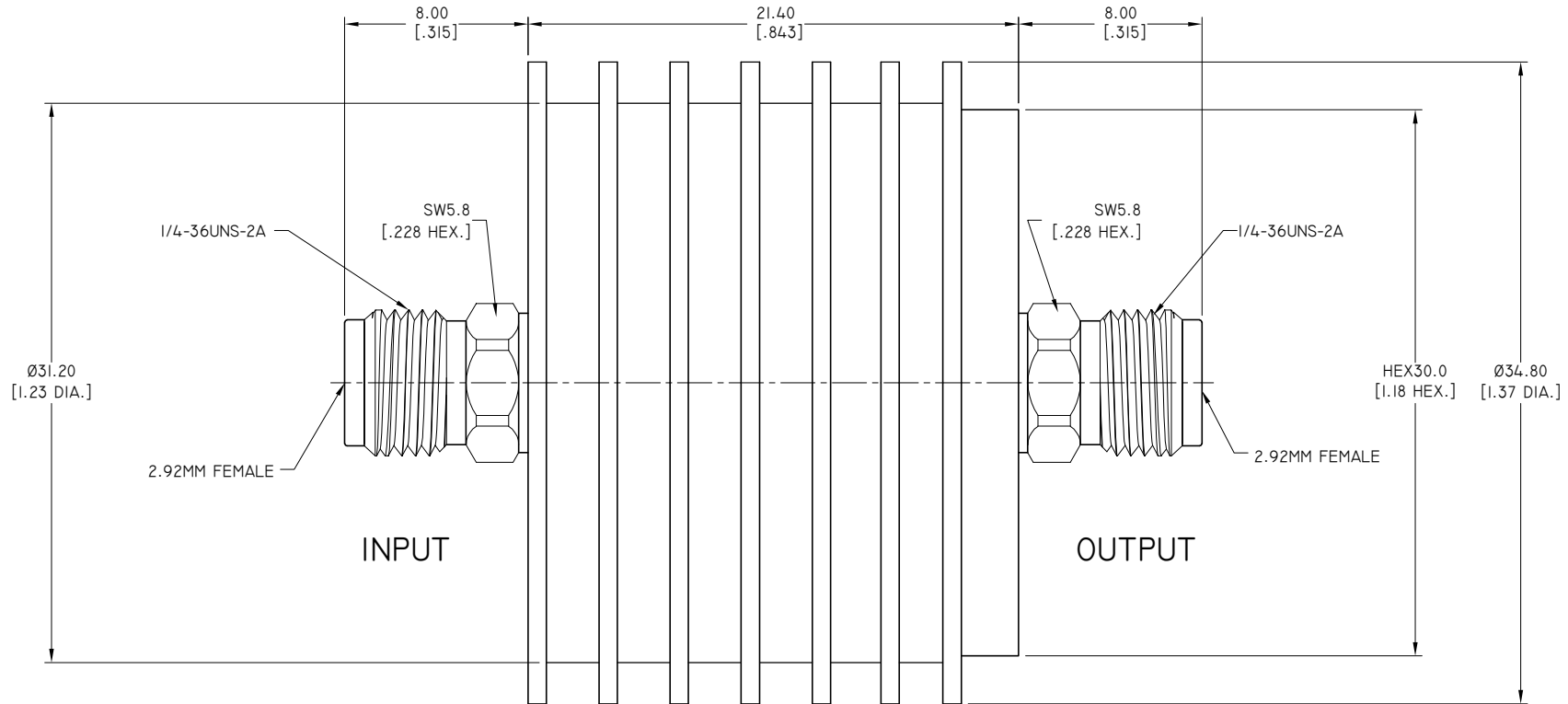

PART NO.	ATTENUATION VALUES & ACCURACY			
	3~10 DB	20 DB	30 DB	40 DB
ANO 29-I504-XX	+1.5 -1.2 DB	±1.0 DB	±1.0 DB	±1.0 DB

NOTE: XX REFER TO ATTENUATION VALUE IN DB

DRAWN	W. YANG	DATE	12/16/21
CHECKED	L. YANG	DATE	12/16/21
APPROVED	J. QU	DATE	12/16/21
UNLESS OTHERWISE SPECIFIED DIMENSIONS ARE IN MILLIMETERS, DIMENSIONS IN [] ARE IN INCHES FOR CUSTOMER REFERENCE ONLY UNLESS OTHERWISE SPECIFIED TOLERANCE ARE:		THESE DRAWINGS AND SPECIFICATIONS ARE THE PROPERTY OF ANOISON ELECTRONICS LTD AND SHOULD NOT BE USED WITHOUT WRITTEN PERMISSION COPYRIGHT © 2021 ANOISON ELECTRONICS LTD	
.XX	±0.13 [0.005"]		
.X	±0.25 [0.010"]		
X	±0.50 [0.019"]		
.X°	±1°		
X°	±2°		



TITLE
ATTENUATOR 2.92MM FEMALE TO 2.92MM FEMALE
15 WATT, UNI-DIRECTIONAL, DC~40GHZ

VIEW	PART NO. ANO 29-I504-XX			
	SIZE A3	SCALE 5:1	SHEET 1/1	REV. A