

4 3 2 1

MATERIAL & FINISH

- 1 BODY: STAINLESS STEEL, PASSIVATED
- 2 CENTER CONTACT: BERYLLIUM COPPER ALLOY, GOLD PLATED
- 3 INSULATOR: PEI

ENVIRONMENTAL DATA:

- 1 TEMPERATURE RANGE: -55°C~+125°C
- 2 2011/65/EU (RoHS): COMPLIANT

ELECTRICAL DATA:

- 1 IMPEDANCE: 50 OHMS
- 2 FREQUENCY RANGE: DC~40 GHZ

REVISIONS			
REV.	DESCRIPTION	DATE	APPROVED
A	INITIAL RELEASE	03/16/21	J. QU

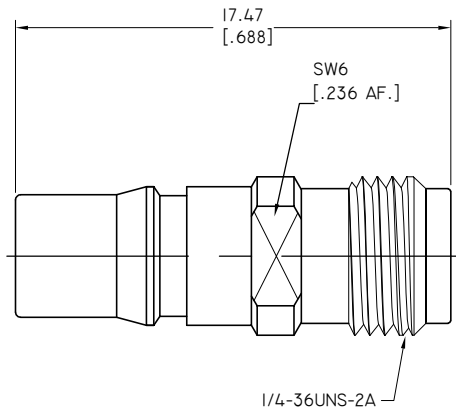

DRAWN	W. YANG	DATE	03/16/21
CHECKED	X. B. YANG	DATE	03/16/21
APPROVED	J. QU	DATE	03/16/21
UNLESS OTHERWISE SPECIFIED DIMENSIONS ARE IN MILLIMETERS, DIMENSIONS IN [] ARE IN INCHES FOR CUSTOMER REFERENCE ONLY UNLESS OTHERWISE SPECIFIED TOLERANCE ARE:		THESE DRAWINGS AND SPECIFICATIONS ARE THE PROPERTY OF ANOISON ELECTRONICS LTD AND SHOULD NOT BE USED WITHOUT WRITTEN PERMISSION COPYRIGHT © 2021 ANOISON ELECTRONICS LTD	
.XX	±0.13 [.005"]		
.X	±0.20 [.008"]		
X	±0.50 [.019"]		
X°	±1°		
X"	±2°		



TITLE
ADAPTER, QK29 FEMALE TO 2.92 FEMALE

PART NO.
ANO 262-292-I564

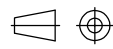
VIEW

SIZE A3	SCALE 5:1	SHEET 1/1	REV. A
-------------------	---------------------	---------------------	------------------

4 3 2 1