

- 1.0 MATERIAL & FINISH:  
 1.1 BODY: BRASS, ALBALOY PLATED  
 1.2 CENTER CONTACT: BERYLLIUM COPPER ALLOY, GOLD PLATED  
 1.3 INSULATOR: PTFE  
 1.4 WASHER: PHOSPHOR BRONZE: ALBALOY PLATED  
 1.5 FASTENING NUT: BRASS, ALBALOY PLATED  
 1.6 O-RING: MVQ(SILICONE RUBBER)

- 2.0 ELECTRICAL DATA:  
 2.1 IMPEDANCE: 50 Ω  
 2.2 FREQUENCY RANGE: DC~6GHZ  
 2.3 VSWR: ≤1.30

- 3.0 ENVIRONMENTAL DATA:  
 3.1 TEMPERATURE RANGE: -55°C~+155°C  
 3.2 2011/65/EU ( RoHS): COMPLIANT

REVISIONS			
REV.	DESCRIPTION	DATE	APPROVED
A	INITIAL RELEASE	08/07/13	J. QU
B	DRAWING FORMAT CHANGED	09/05/17	J. QU

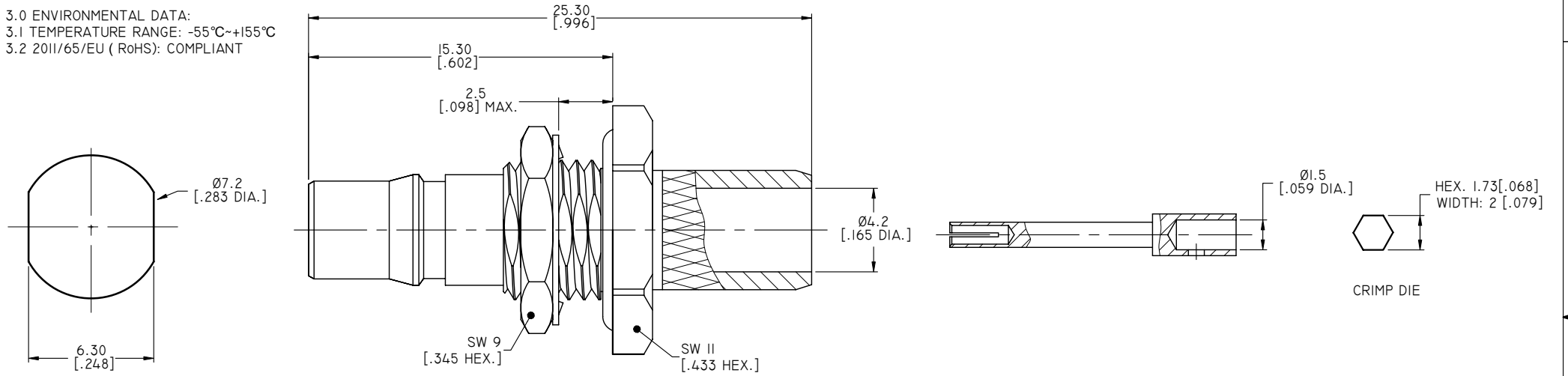

RECOMMENDED MOUNTING HOLE

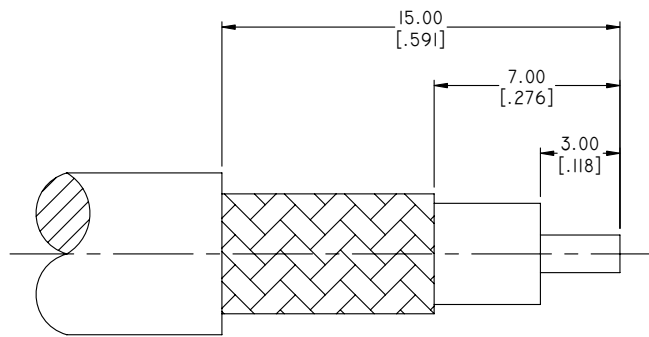
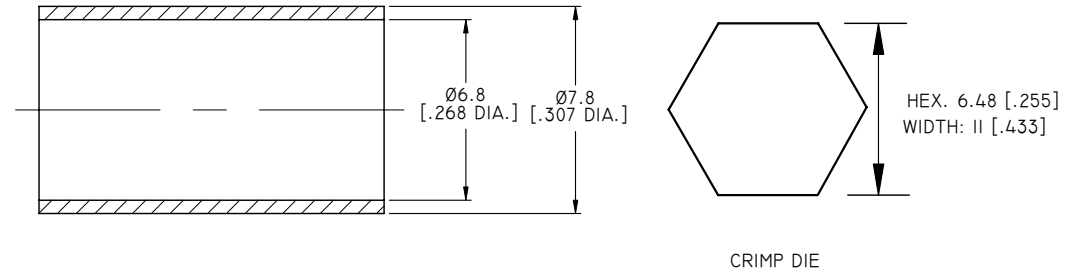

CABLE STRIPPING DIMENSIONS

DRAWN	L. YANG	DATE	09/05/17
CHECKED	X. B. YANG	DATE	09/05/17
APPROVED	J. QU	DATE	09/05/17
UNLESS OTHERWISE SPECIFIED DIMENSIONS ARE IN MILLIMETERS, DIMENSIONS IN [ ] ARE IN INCHES FOR CUSTOMER REFERENCE ONLY UNLESS OTHERWISE SPECIFIED TOLERANCE ARE:		THESE DRAWINGS AND SPECIFICATIONS ARE THE PROPERTY OF ANOISON ELECTRONICS LTD AND SHOULD NOT BE USED WITHOUT WRITTEN PERMISSION COPYRIGHT © 2017 ANOISON ELECTRONICS LTD	
.XX	±0.13 [.005"]		
.X	±0.20 [.008"]		
X	±0.50 [.019"]		
X°	±1°		
X°	±2°		

**ANOISON**  
 ...we create connection for technologies

TITLE  
 QMA STRAIGHT WATERPROOF BULKHEAD FEMALE CRIMP FOR LMR240

VIEW

PART NO.  
 ANO 2612-1092

SIZE	A3	SCALE	5:1	SHEET	I/I	REV.	B
------	----	-------	-----	-------	-----	------	---