

MATERIAL & FINISH:

- 1 BODY: STAINLESS STEEL, PASSIVATED
- 2 CENTER CONTACT: BERYLLIUM COPPER ALLOY, GOLD PLATED
- 3 SOLDER FERRULE: BRASS, GOLD PLATED
- 4 CLAMP NUT: STAINLESS STEEL, PASSIVATED
- 5 LOCK WASHER: BERYLLIUM COPPER ALLOY, NICKEL PLATED
- 6 INSULATOR: PEI

ELECTRICAL DATA:

- 1 IMPEDANCE: 50 Ω
- 2 FREQUENCY RANGE: DC~50 GHz
- 3 VSWR: 1.40 MAX.

ENVIRONMENTAL DATA:

- 1 TEMPERATURE RANGE: -55°C~+125°C
- 2 2011/65/EU (RoHS): COMPLIANT

REVISIONS			
REV.	DESCRIPTION	DATE	APPROVED
A	INITIAL RELEASE	11/17/17	J. QU

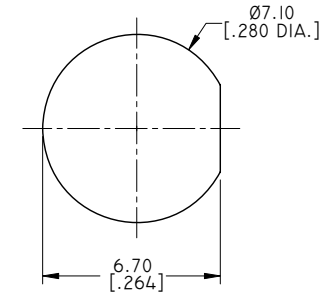
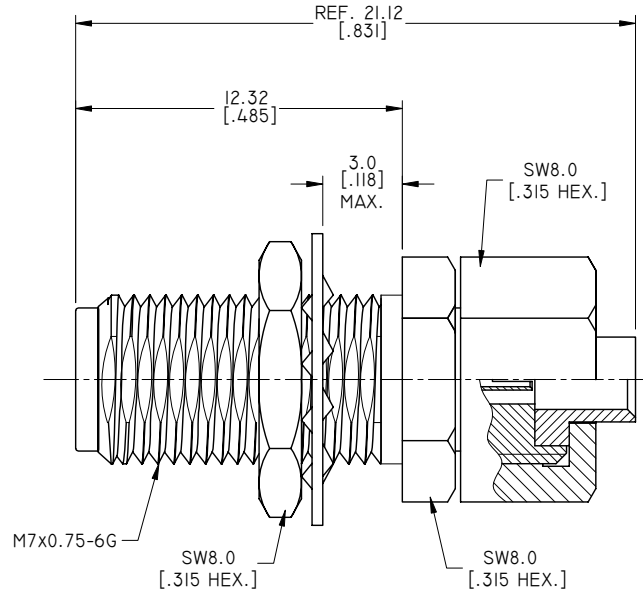

RECOMMENDED MOUNTING HOLE

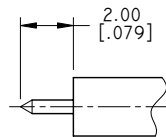

CABLE STRIPPING DIMENSIONS

DRAWN	X. B. YANG	DATE	11/17/17
CHECKED	W. YANG	DATE	11/17/17
APPROVED	J. QU	DATE	11/17/17
UNLESS OTHERWISE SPECIFIED DIMENSIONS ARE IN MILLIMETERS. DIMENSIONS IN [] ARE IN INCHES FOR CUSTOMER REFERENCE ONLY UNLESS OTHERWISE SPECIFIED TOLERANCE ARE:		THESE DRAWINGS AND SPECIFICATIONS ARE THE PROPERTY OF ANOISON ELECTRONICS LTD AND SHOULD NOT BE USED WITHOUT WRITTEN PERMISSION COPYRIGHT © 2017 ANOISON ELECTRONICS LTD	
.XX	±0.13 [.005"]		
.X	±0.25 [.010"]		
X	±0.50 [.019"]		
.X°	±1°		
X°	±2°		



TITLE			
2.4MM STRAIGHT BULKHEAD FEMALE SOLDER FOR .086 CABLE, CAPTIVATED CONTACT			
VIEW		PART NO.	
		ANO 2212-1026	
SIZE	SCALE	SHEET	REV.
A3	5:1	1/1	A