

REVISIONS			
REV.	DESCRIPTION	DATE	APPROVED
A	INITIAL RELEASE	11/17/17	J. QU

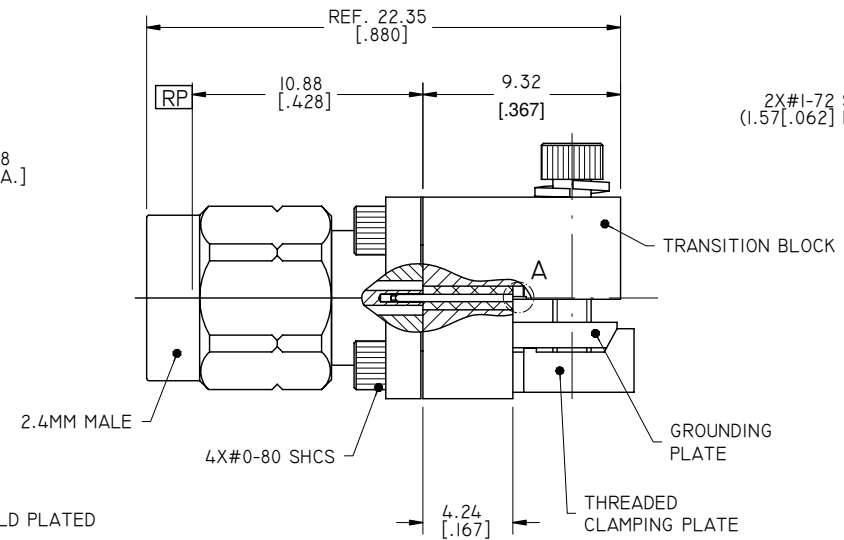

2X#1-72 SHCS X 5/16"L
(1.57 [.062] HEX. SOCKET)

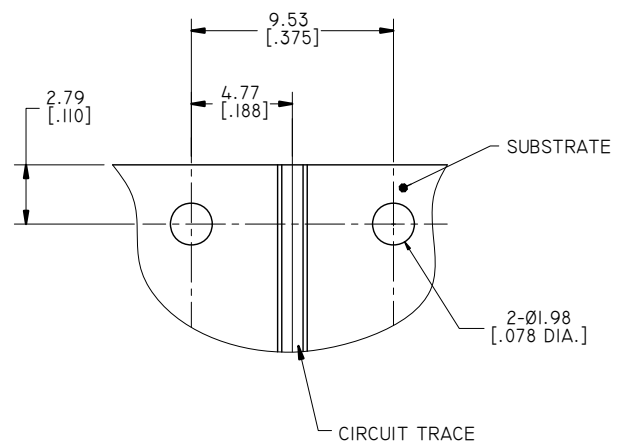
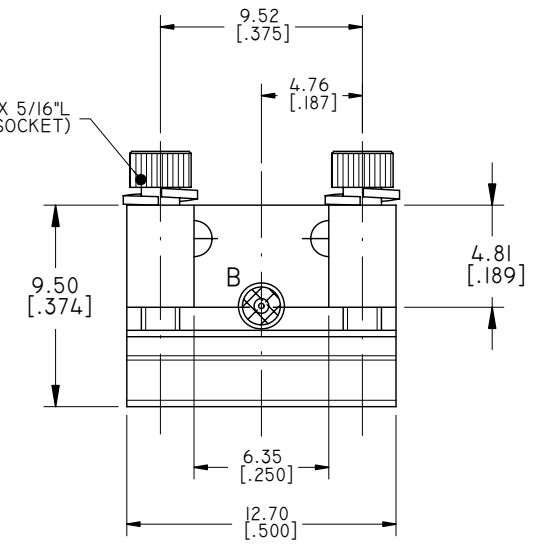

- 2.4MM CONNECTOR**
1. BODY: STAINLESS STEEL, PASSIVATED
 2. CENTER CONTACT: BERYLLIUM COPPER ALLOY, GOLD PLATED
 3. INSULATOR: PEI
 4. COUPLING NUT: STAINLESS STEEL, PASSIVATED

- TRANSITION BLOCK**
1. TRANSITION BLOCK: BRASS, NICKEL PLATED
 2. GROUNDING PLATE: BRASS, NICKEL PLATED
 3. THREADED CLAMPING PLATE: BRASS, NICKEL PLATED
 4. LAUNCH PIN: BERYLLIUM COPPER ALLOY, GOLD PLATED
 5. TRANSITION BLOCK DIELECTRIC: PTFE

- ENVIRONMENTAL DATA:**
1. TEMPERATURE RANGE: -55°C~+125°C
 2. 2011/65/EU (RoHS): COMPLIANT

- ELECTRICAL SPECIFICATIONS:**
1. IMPEDANCE: 50 Ω
 2. FREQUENCY RANGE: DC~50 GHZ

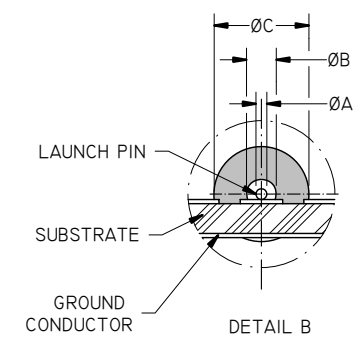
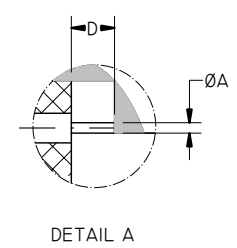

PART NO.	Ø A	Ø B	Ø C	D
ANO 221-A1-H	0.13 [.005]	0.23 [.009]	0.74 [.0290]	0.76 [.030]
ANO 221-A2-H	0.18 [.007]	0.31 [.012]	0.99 [.0390]	0.76 [.030]
ANO 221-A3-H	0.18 [.007]	0.38 [.015]	1.22 [.0480]	0.76 [.030]
ANO 221-A4-H	0.25 [.010]	0.51 [.020]	1.61 [.0635]	1.27 [.050]

DRAWN	W. YANG	DATE	11/17/17
CHECKED	X. B. YANG	DATE	11/17/17
APPROVED	J. QU	DATE	11/17/17
UNLESS OTHERWISE SPECIFIED DIMENSIONS ARE IN MILLIMETERS. DIMENSIONS IN [] ARE IN INCHES FOR CUSTOMER REFERENCE ONLY UNLESS OTHERWISE SPECIFIED TOLERANCE ARE:		THESE DRAWINGS AND SPECIFICATIONS ARE THE PROPERTY OF ANOISON ELECTRONICS LTD AND SHOULD NOT BE USED WITHOUT WRITTEN PERMISSION COPYRIGHT © 2017 ANOISON ELECTRONICS LTD	
.XX	±0.13 [.005"]		
.X	±0.20 [.008"]		
X	±0.50 [.019"]		
.X°	±1°		
X°	±2°		



TITLE
2.4MM MALE END LAUNCH CONNECTOR

VIEW	PART NO. ANO 221-AX-H			
	SIZE A3	SCALE 4:1	SHEET 1/1	REV. A